



WT6000

RS4000/RS5000/RS6000

Series

Accessories Guide

Charging Options

Single Cradles



WT6000 Single Slot Cradle w/Spare Battery Charger:

CRD-NGWT-1S1BU-01: Single slot USB Cradle, w/spare battery charging, charges one wearable terminal and one spare battery.

Allows USB communication to the device with an additional micro-USB cable.

Requires: Power Supply **PWR-BGA12V50W0WW**, DC Line Cord **CBL-DC-388A1-01** and Country Specific 3 wire AC Line Cord.

Additional accessories for single slot cradle



25-124330-01R

Micro-USB to USB Cable for single slot cradle



PWR-BGA12V50W0WW

Level VI AC/DC Power Supply (Brick, replacement for PWRS-14000-148R)

AC Input: 100-240V, 2.4A

DC Output: 12V, 4.16A, 50W

Requires: DC line cord and Country specific grounded AC line cord.



CBL-DC-388A1-01

DC Line Cord for running the single slot cradles or battery chargers from a single Level VI power supply PWR-BGA12V50W0WW, Level VI replacement for PWRS-14000-148R.



23844-00-00R

US AC line cord, 7.5 feet long, grounded, three wire for power supplies.

Charging LED indicators

Off	Battery not charging
Solid Amber	Healthy battery charging
Solid Green	Healthy battery charging complete
Fast Blink Red	Charging error
Solid Red	Unhealthy battery

Charging Options

Single Cradles



RS6000 Single Slot Cradle w/Spare Battery Charger:

CRD-NGRS-1S1BU-01: Single slot USB Cradle, w/spare battery charging, charges one ring scanner and one spare battery.

Allows USB communication to the device with an additional micro-USB cable.

Requires: Power Supply **PWR-BGA12V50W0WW**, DC Line Cord **CBL-DC-388A1-01** and Country Specific 3 wire AC Line Cord.

Additional accessories for single slot cradle



25-124330-01R

Micro-USB to USB Cable for single slot cradle



PWR-BGA12V50W0WW

Level VI AC/DC Power Supply (Brick, replacement for PWRS-14000-148R)

AC Input: 100-240V, 2.4A

DC Output: 12V, 4.16A, 50W

Requires: DC line cord and Country specific grounded AC line cord.



CBL-DC-388A1-01

DC Line Cord for running the single slot cradles or battery chargers from a single Level VI power supply PWR-BGA12V50W0WW, Level VI replacement for PWRS-14000-148R.



23844-00-00R

US AC line cord, 7.5 feet long, grounded, three wire for power supplies.

Charging LED indicators

Off	Battery not charging
Solid Amber	Healthy battery charging
Solid Green	Healthy battery charging complete
Fast Blink Red	Charging error
Solid Red	Unhealthy battery

Charging Options

Two-Slot Cradle



WT6000/RS6000 Two Slot Cradle:

CRD-NWTRS-2SUCH-01: 2slot USB Cradle, charges one wearable terminal and one ring scanner.

Allows USB communication to each device with an additional micro-USB cable.

Requires: Power Supply **PWR-BGA12V50W0WW**, DC Line Cord **CBL-DC-388A1-01** and Country Specific 3 wire AC Line Cord.

Additional accessories for single slot cradle



25-124330-01R

Micro-USB to USB Cable for single slot cradle



PWR-BGA12V50W0WW

Level VI AC/DC Power Supply (Brick, replacement for PWRS-14000-148R)

AC Input: 100-240V, 2.4A

DC Output: 12V, 4.16A, 50W

Requires: DC line cord and Country specific grounded AC line cord.



CBL-DC-388A1-01

DC Line Cord for running the single slot cradles or battery chargers from a single Level VI power supply PWR-BGA12V50W0WW, Level VI replacement for PWRS-14000-148R.



23844-00-00R

US AC line cord, 7.5 feet long, grounded, three wire for power supplies.

Charging LED indicators

Off	Battery not charging
Solid Amber	Healthy battery charging
Solid Green	Healthy battery charging complete
Fast Blink Red	Charging error
Solid Red	Unhealthy battery

Charging Options

Five-Slot Cradles



Five-Slot Cradle options:

CRD-NGWT-5S5BC-01: WT6000 5Slot Charge Only Cradle w/Spare Battery Charger, charges up to 5 wearable terminals and 5 spare batteries.

CRD-NGRS-5S5BC-01: RS6000 5Slot Charge Only Cradle w/Spare Battery Charger, charges up to 5 ring scanners and 5 spare batteries.

CRD-NGWT-5S5BE-01: WT6000 5Slot Ethernet Cradle w/Spare Battery Charger, charges up to 5 ring scanners and 5 spare batteries.

CRD-NGRS-5S5BE-01: RS6000 5Slot Ethernet Cradle w/Spare Battery Charger, charges up to 5 ring scanners and 5 spare batteries.

All Cradles Require: Power Supply **PWR-BGA12V108W0WW**, DC Cord **CBL-DC-381A1-01** and Country Specific 3 wire AC Line Cord.

Additional accessories



PWR-BGA12V108W0WW

Level VI AC/DC Power Supply (Brick, Replacement for PWR-14000-241R)

AC Input: 100-240V, 2.8A

DC Output: 12V, 9A, 108W

Requires: DC line cord and Country specific grounded AC line cord.



CBL-DC-381A1-01

DC Line Cord for running multi-slot cradles from a single Level VI power supply PWR-BGA12V108W0WW, Level VI replacement for PWR-14000-241R



23844-00-00R

US AC line cord, 7.5 feet long, grounded, three wire for power supplies.



BRKT-SCRD-SMRK-01

Rack/Wall Mounting bracket for multi-slot cradles.

Charging LED indicators

Off	Battery not charging
Solid Amber	Healthy battery charging
Solid Green	Healthy battery charging complete
Fast Blink Red	Charging error
Solid Red	Unhealthy battery

Charging Options

Ten-Slot Cradles



Ten-Slot Cradle options:

CRD-NWTRS-10SCH-01: WT6000/RS6000 10Slot Charge Only Cradle, charges up to 5 wearable terminals and 5 ring scanners.

CRD-NGWT-10SCH-01: WT6000 10Slot Charge Only Cradle, charges up to 10 wearable terminals.

CRD-NGRS-10SCH-01: RS6000 10Slot Charge Only Cradle, charges up to 10 ring scanners

All Cradles Require: Power Supply **PWR-BGA12V108W0WW**, DC Cord **CBL-DC-381A1-01** and Country Specific 3 wire AC Line Cord.

Additional accessories



PWR-BGA12V108W0WW

Level VI AC/DC Power Supply (Brick, Replacement for PWRS-14000-241R)

AC Input: 100-240V, 2.8A

DC Output: 12V, 9A, 108W

Requires: DC line cord and Country specific grounded AC line cord.



CBL-DC-381A1-01

DC Line Cord for running multi-slot cradles from a single Level VI power supply PWR-BGA12V108W0WW, Level VI replacement for PWRS-14000-241R



23844-00-00R

US AC line cord, 7.5 feet long, grounded, three wire for power supplies.



BRKT-SCRD-SMRK-01

Rack/Wall Mounting bracket for multi-slot cradles.

Charging LED indicators

Off	Battery not charging
Solid Amber	Healthy battery charging
Solid Green	Healthy battery charging complete
Fast Blink Red	Charging error
Solid Red	Unhealthy battery

Multi-Slot Cradle Installations



Battery / battery charging accessories

3350 mAh Battery



BTRY-NWTRS-33MA-01

PowerPrecision+ Lithium Ion battery, 3350 mAh. Advanced battery technology, provides higher level of intelligence (State of Charge and State of Health) for wearable terminal or ring scanner.

Spare Battery Charging Options:



SAC-NWTRS-4SCH-01: 4-slot battery charger, charges four spare batteries. **Requires:** Power Supply **PWR-BGA12V50W0WW**, DC Line Cord **CBL-DC-388A1-01** and Country Specific 3 wire AC Line Cord.



SAC-NWTRS-20SCH-01: 20-slot battery charger, charges 20 spare batteries. **Requires:** Power Supply **PWR-BGA12V108W0WW**, DC Cord **CBL-DC-381A1-01** and Country Specific 3 wire AC Line Cord.

Accessories for battery chargers:



PWR-BGA12V50W0WW

Level VI AC/DC Power Supply

AC Input: 100-240V, 2.4A

DC Output: 12V, 4.16A, 50W

Requires: DC line cord and Country specific grounded AC line cord.



CBL-DC-388A1-01

DC Line Cord for running the single slot cradles or battery chargers from a single Level VI power supply PWR-BGA12V50W0WW.



PWR-BGA12V108W0WW

Level VI AC/DC Power Supply

AC Input: 100-240V, 2.8A

DC Output: 12V, 9A, 108W

Requires: DC line cord and Country specific grounded AC line cord.



CBL-DC-381A1-01

DC Line Cord for running multi-slot cradles from a single Level VI power supply PWR-BGA12V108W0WW.



23844-00-00R

US AC line cord, 7.5 feet long, grounded, three wire for power supplies.



BRKT-SCRD-SMRK-01

Rack/Wall Mounting bracket for multi-slot cradles and 20slot battery charger.

Cables/Adapters

USB/Charge Cable

CBL-NGWT-USBCHG-01

Provides USB communication and charge to the wearable terminal.

Requires: Power supply **PWR-BUA5V16W0WW**, DC Line Cord **CBL-DC-383A1-01** and un-grounded country specific AC line cord.



Audio Cables

CBL-NGWT-AUQDLG-01

Audio adapter cable, compatible with quick-disconnect wired headsets. Compatible while the device is worn on the hip.

Requires: QD headset.



CBL-NGWT-AUQDST-01

Audio adapter cable, compatible with quick-disconnect wired headsets. Compatible while the device is worn on the wrist.

Requires: QD headset.



Other Cables

CBL-NGWT-HDV BAP-01

Vibrating cable, connects directly to the wearable terminal and provides additional haptic feedback to the user.



PWR-BUA5V16W0WW

Level VI AC/DC Power Supply

AC Input: 100-240V, 0.6A

DC Output: 5.4V, 3A, 16W

Requires: DC line cord and Country specific un-grounded AC line cord.



CBL-DC-383A1-01

DC Line Cord for running single slot cradles or charging cables from a single Level VI power supply PWR-BUA5V16W0WW.



50-16000-182R

US AC line cord, un-grounded, two-wire.



RCH51

Rugged wired headset with quick-disconnect



25-129938-02R

Training cable - connects two wired headsets to one mobile computer

Soft-Goods

Wearable Terminal



Wrist Mount options:

SG-NGWT-WRMTS-01: WT6000 Wrist Mount, includes carrier, comfort pad and small/medium strap.

SG-NGWT-WRMTL-01: WT6000 Wrist Mount, includes carrier, comfort pad and medium/large strap.

Additional accessories



SG-NGWT-WSTPST-01

Spare replacement strap for wrist mount (small/medium)



SG-NGWT-WSTPLN-01

Spare replacement strap for wrist mount (medium/large)



SG-WT4027050-01R

Optional arm sleeves for wrist mount (pack of 5)



SG-NGWT-CMPD-01

Replacement comfort pad for wrist mount.



SG-NGWT-HPMNT-01

Hip-mount for wearable terminal, allows to use the device on the hip.

Soft-Goods: Wrist Mount



- **Velcro removed**
- **One Adjustable strap instead of two**
- **Integrated BOA closure system**
 - Strong
 - Durable
 - Easy to use
- **Specific Materials chosen for hygienic reasons**
 - Can be cleaned down on site
 - Non absorbent



BOA closure system

Specific Materials chosen for grip and wipe down qualities

Soft-Goods: Comfort Pad

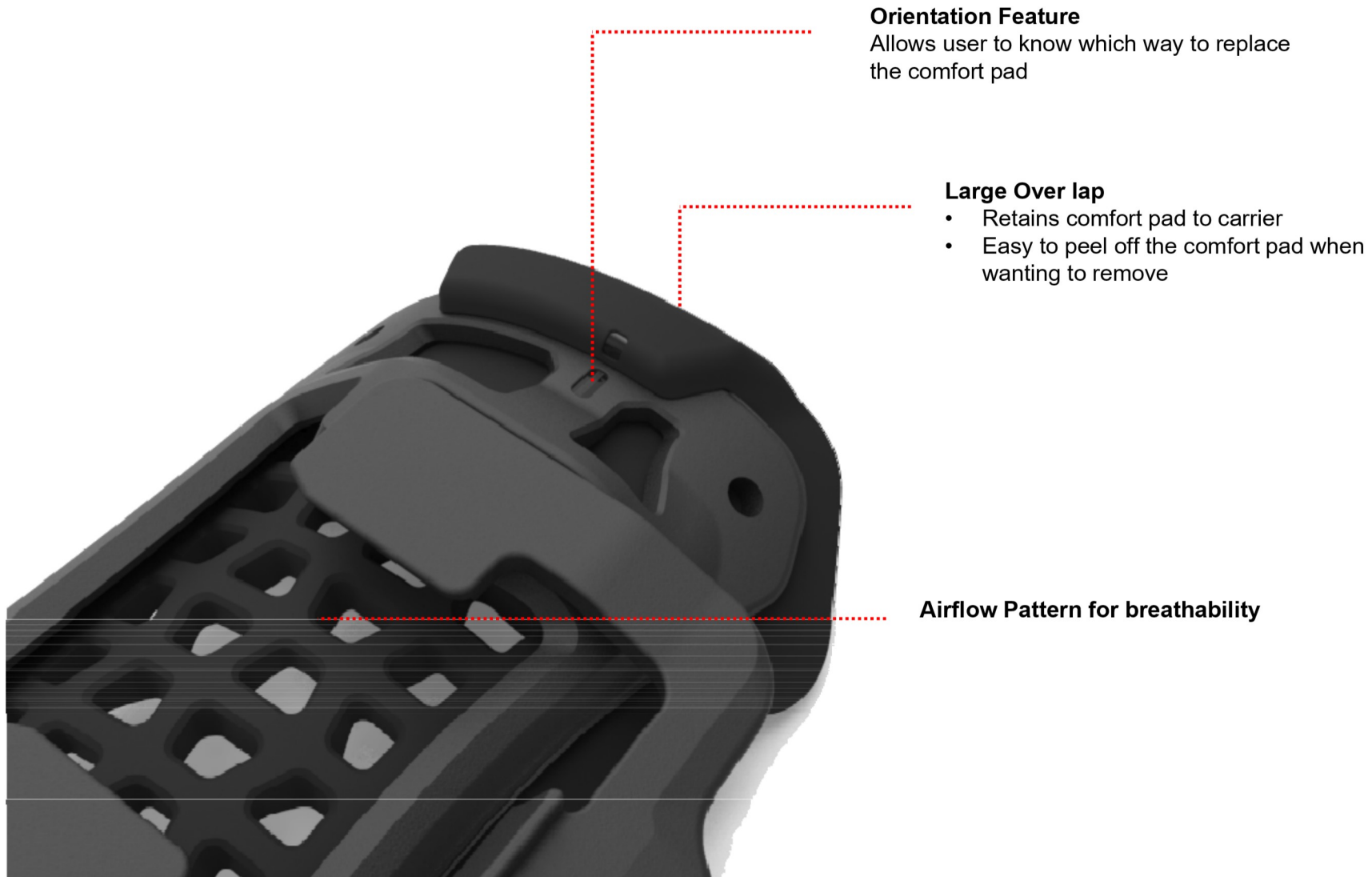

Soft-Goods: Wrist Strap



Improved ease of removal of strap from carrier

Retaining Rib holding elastic cord in place when not under load

Two size straps to cover the many various sizes of users

Small Strap

Large Strap



White Dial and accent colour call out for Small Strap Identification

Black Dial and accent colour call out for Large Strap Identification

Soft-Goods

RS4000 Ring Scanner

Spare Accessories for RS4000 Ring Scanner



21-93022-03R

RS5000 Standard Spare Finger Strap
(Single Pack, 6" length)



SG-RS419-FGSTP-02R

RS5000 Extended Spare Finger Strap
(Single Pack, 7.8" length)



SG-RS419-TRGAS-01R

RS5000 Replacement Trigger
Assembly

Soft-Goods

RS5000 Ring Scanner

Spare Accessories for RS5000 Ring Scanner



SG-NGRS-SFSVS-01R

RS5000 Standard Spare Finger Strap
(Single Pack, 6" length)



SG-RS419-FGSTP-02R

RS5000 Extended Spare Finger Strap
(Single Pack, 7.8" length)



SG-NGRS-SFRVPD-05

RS5000 Replacement Velcro
Pads for Wrist Mount
(Pack of 5 units)



SG-NGRS-TRGASR-01R

RS5000 Replacement Trigger
Assembly

Soft-Goods

RS6000 Ring Scanner

Spare Accessories for RS6000 Ring Scanner



SG-NGRS-STRPKV-10

RS6000 Spare velcro finger straps for trigger configuration (pack of 10 units). Order buckles SG-NGRS-STBKLV-10 separately.



SG-NGRS-TRGA-01

RS6000 replacement trigger swivel assembly. Order finger straps SG-NGRS-STRPKV-10 and buckles SG-NGRS-STBKLV-10 separately



SG-NGRS-STRP2VK-10

RS6000 spare velcro finger straps for trigger-less configuration (10-pack). Order buckles SG-NGRS-STBKL-10 separately.



SG-NGRS-CMPD-01

RS6000 Replacement comfort pads, to be used with manual trigger and trigger-less configurations. Pack includes front and back comfort pads.



SG-NGRS-STBKLV-10

RS6000 Spare buckles for velcro finger strap (pack of 10 units) Order velcro finger straps separately, use one buckle with trigger configuration and two buckles with trigger-less configuration.



SG-NGRS-TRLH-01

RS6000 Replacement strap holder, for trigger-less configurations. Order finger straps SG-NGRS-STRP2VK-10 and buckles SG-NGRS-STBKLV-10 separately

WT6300

Wearable Computer

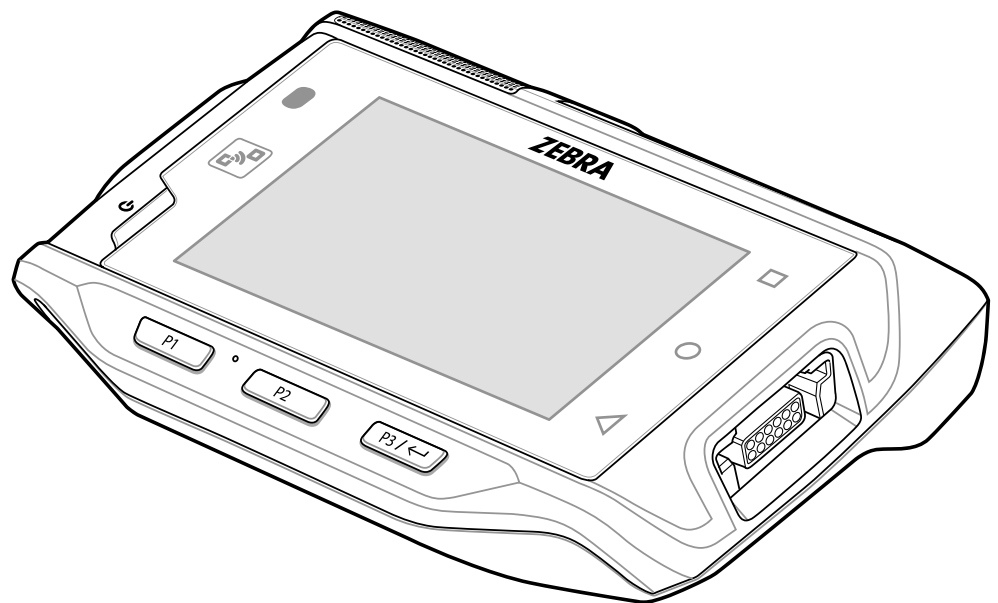

ZEBRA

Product Reference Guide for Android™ 10

ZEBRA and the stylized Zebra head are trademarks of Zebra Technologies Corporation, registered in many jurisdictions worldwide. Google, Android, Google Play and other marks are trademarks of Google LLC. All other trademarks are the property of their respective owners.

© 2021 Zebra Technologies Corporation and/or its affiliates. All rights reserved.

For further information regarding legal and proprietary statements, go to:

COPYRIGHTS: www.zebra.com/copyright

WARRANTY: www.zebra.com/warranty

END USER LICENSE AGREEMENT: www.zebra.com/eula

Terms of Use

Proprietary Statement

This manual contains proprietary information of Zebra Technologies Corporation and its subsidiaries (“Zebra Technologies”). It is intended solely for the information and use of parties operating and maintaining the equipment described herein. Such proprietary information may not be used, reproduced, or disclosed to any other parties for any other purpose without the express, written permission of Zebra Technologies.

Product Improvements

Continuous improvement of products is a policy of Zebra Technologies. All specifications and designs are subject to change without notice.

Liability Disclaimer

Zebra Technologies takes steps to ensure that its published Engineering specifications and manuals are correct; however, errors do occur. Zebra Technologies reserves the right to correct any such errors and disclaims liability resulting therefrom.

Limitation of Liability

In no event shall Zebra Technologies or anyone else involved in the creation, production, or delivery of the accompanying product (including hardware and software) be liable for any damages whatsoever (including, without limitation, consequential damages including loss of business profits, business interruption, or loss of business information) arising out of the use of, the results of use of, or inability to use such product, even if Zebra Technologies has been advised of the possibility of such damages. Some jurisdictions do not allow the exclusion or limitation of incidental or consequential damages, so the above limitation or exclusion may not apply to you.

Revision History

Changes to the original guide are listed below:

Change	Date	Description
-01 Rev A	10/2020	Initial release.
-02 Rev A	10/2021	Updated GSM Restricted topic.

Contents

About This Guide	11
Configurations	11
Notational Conventions	12
Icon Conventions	12
Service Information	12
Determining Software Versions.....	13
Determining the Serial Number.....	13
Getting Started	14
Unpacking.....	14
Device Features	15
Setting up the Device	16
Installing the Battery	17
Charging the Battery	17
Charging Indicators	17
Charging Temperature	18
Installing the Wrist Mount.....	19
Connecting a Scanner.....	20
Replacing the Battery.....	21
Using the Device	23
Home Screen	23
Setting Home Screen Rotation	23
Status Bar	24
Notification Icons.....	24
Status Icons	25
Managing Notifications	26
Opening the Quick Access Panel	26
Quick Access Panel Icons.....	27
Editing Icons on the Quick Settings Bar	27

Battery Management.....	27
Checking Battery Status	28
Monitoring Battery Usage	28
Low Battery Notification	28
Waking the Device	28
USB Communication.....	29
Transferring Files.....	29
Transferring Photos	29
Disconnect from the Host Computer	29
Settings.....	30
Accessing Settings.....	30
Display Settings	30
Setting the Screen Brightness Manually.....	30
Setting the Screen Brightness Automatically.....	30
Setting Night Light	30
Setting Screen Rotation.....	31
Setting Screen Timeout	31
Lock Screen Display	31
Setting Font Size	32
Setting the Date and Time	32
General Sound Setting.....	33
Sound Options.....	33
Setting Wake-Up Sources.....	33
Remapping a Button	34
Remappable Keys.....	34
Keyboards	35
Keyboard Configuration.....	35
Enabling Keyboards	35
Switching Between Keyboards.....	35
Using the Android and Gboard Keyboards.....	35
Edit Text	35
Entering Numbers, Symbols, and Special Characters	35
Keypad.....	36
Language Usage.....	38
Changing the Language Setting	38
Adding Words to the Dictionary	38
Notifications.....	38
Setting App Notifications	38
Viewing Notification Settings for All Apps	39
Controlling Lock Screen Notifications	39
Blink Light.....	39

Applications	41
Accessing Apps.....	42
Switching Between Recent Apps.....	42
Battery Manager.....	43
Opening Battery Manager	43
Battery Manager Information	43
DataWedge Demonstration.....	45
Scanner Selection	45
PTT Express Voice Client.....	46
PTT Express User Interface	46
PTT Audible Indicators	46
PTT Notification Icons	47
Enabling PTT Communication.....	47
Selecting a Talk Group.....	47
PTT Communication.....	47
Creating a Group Call	48
Responding with a Private Response	48
Disabling PTT Communication	48
RxLogger.....	49
RxLogger Configuration.....	49
Configuration File	49
Enabling Logging.....	49
Disabling Logging	49
Extracting Log Files	49
Backing Up	49
RxLogger Utility	50
Initiating the Main Chat Head.....	50
Removing the Main Chat Head	50
Viewing Logs.....	50
Removing a Sub Chat Head Icon.....	50
Backing Up In Overlay View.....	50
Sound Recorder	50
 Data Capture	 52
Introduction	52
Laser Scanning	52
Scanning Bar Codes.....	52
Imaging	52
Operational Modes	53
RS4000 Ring Scanner	53
RS5000 Ring Scanner	53
RS5100 Ring Scanner	54

RS6000 Bluetooth Ring Scanner	54
RS507/X Hands-Free Imager.....	54
Scanning Considerations	55
Bar Code Capture with RS4000.....	55
Adaptive Scanning	56
Bar Code Capture with RS5000 Corded Imager.....	56
Scanning with RS5100 Ring Scanner	57
Bar Code Capture with RS6000 Hands-Free Imager.....	58
Bar Code Capture with RS507/X Hands-Free Imager	59
Pairing the RS507/X or RS6000 Hands-Free Imager	61
Pairing Using Near Field Communication.....	61
Pairing in HID Mode Using Near Field Communication.....	62
Pairing Using Simple Serial Interface	63
Pairing Using Bluetooth Human Interface Device	64
DataWedge	65
Enabling DataWedge.....	65
Disabling DataWedge.....	65
Supported Decoders.....	65
Wireless	68
Wireless Local Area Networks	68
Connecting to a Wi-Fi Network.....	69
Removing a Wi-Fi Network.....	69
WLAN Configuration	69
Configuring a Secure Wi-Fi Network	69
Manually Adding a Wi-Fi Network	70
Configuring for a Proxy Server	71
Configuring the Device to Use a Static IP Address	72
Wi-Fi Preferences.....	72
Additional Wi-Fi Settings	73
Wi-Fi Direct.....	73
Bluetooth.....	73
Adaptive Frequency Hopping	74
Security.....	74
Bluetooth Profiles	74
Bluetooth Power States	75
Bluetooth Radio Power.....	75
Enabling Bluetooth.....	76
Disabling Bluetooth	76
Discovering Bluetooth Device(s)	76
Changing the Bluetooth Name	76

Connecting to a Bluetooth Device	76
Selecting Profiles on the Bluetooth Device	77
Unpairing a Bluetooth Device	77
Cast.....	77
Near Field Communications.....	77
Reading NFC Cards	78
Enterprise NFC Settings.....	78
Accessories.....	80
Battery Charging	82
Main Battery Charging	82
Spare Battery Charging	82
Charging Temperature	83
1-Slot USB Charging Cradle	84
Setup	85
Charging the Device	86
Charging the Spare Battery	86
Battery Removal.....	87
2-Slot Device/RS6000 Charging Cradle.....	88
Setup	89
Charging the RS6000	89
5-Slot Charge Only Cradle	91
Setup	92
Charging the Device	93
Charging the Spare Battery	93
Battery Removal.....	94
10-Slot Device/RS6000 Charge Only Cradle.....	95
Setup	96
Charging the Device	97
Charging the RS6000	97
10-Slot Charge Only Cradle	99
Setup	100
Charging the Device	101
5-Slot Ethernet Cradle.....	102
Setup	103
Establishing Ethernet Communication.....	103
Ethernet LED Indicators	104
Daisy-chaining Ethernet Cradles	104
Ethernet Settings	105
Configuring Ethernet Proxy Settings	105
Configuring Ethernet Static IP Address	106

LED Indicators	106
Establishing Ethernet Connection	107
4-Slot Spare Battery Charger	108
Setup	108
Charging the Spare Battery	109
Battery Removal	109
20-Slot Spare Battery Charger	110
Setup	111
Charging the Spare Battery	111
Battery Removal	112
USB and Charging Cable	112
Attaching the USB and Charging Cable	113
Removing the USB and Charging Cable	113
Keypad	114
Installing the Keypad	114
Replacing the Keypad Mount	116
Hip Mount	120
Routing an Extended Cable Scanner	121
Quick Disconnect Audio Cables	122
Attaching the Audio Adapter	122
Connecting the Audio Cable to a Headset	123
Removing the Audio Adapter	124
Vibrator Cable	124
RS4000 Scanner	125
RS5000 Imager	127
5-Slot Cradle Rack Installation	129
4-Slot Battery Chargers Rack Installation	132
Rack Mount Installation	135
5-Slot Cradle Wall Installation	138
Bottom Tray Assembly	138
Bracket Wall Mounting	138
4-Slot Battery Charger Wall Installation	140
Bottom Tray Assembly	140
Bracket Wall Mounting	140
Application Deployment	142
Security	142
Secure Certificates	142
Installing a Secure Certificate	142
Configuring Credential Storage Settings	143
Development Tools	143

Android Application Development	143
Development Workstation	143
Enabling Developer Options	143
EMDK for Android.....	144
StageNow	144
GMS Restricted.....	144
ADB USB Setup	144
Enabling USB Debugging.....	144
Application Installation	145
Installing Applications Using the USB Connection	145
Installing Applications Using the Android Debug Bridge	146
Uninstalling an Application	146
Performing a System Update.....	146
Downloading the System Update Package	146
Performing a System Update Using ADB.....	147
Verifying System Update Installation.....	147
Enterprise Reset	147
Performing an Enterprise Reset From Device Settings.....	147
Downloading the Enterprise Reset Package	148
Performing an Enterprise Reset Using ADB.....	148
Performing a Factory Reset	148
Downloading the Factory Reset Package	148
Performing a Factory Reset Using ADB	149
Storage.....	149
Random Access Memory	149
Viewing Memory.....	150
Internal Storage.....	150
Viewing Internal Storage.....	150
Enterprise Folder.....	150
Managing Apps	150
App Details	150
Managing Downloads.....	151
Maintenance and Troubleshooting	152
Maintaining the Device.....	152
Battery Safety Guidelines.....	152
Cleaning Instructions.....	153
Approved Cleanser Active Ingredients	153
Harmful Ingredients	153
Device Cleaning Instructions	153
Special Cleaning Notes	154

Cleaning Materials Required	154
Cleaning Frequency	154
Cleaning the Device	154
Housing	154
Display	154
Exit Window	154
Cleaning Cradle Connectors	155
Cleaning the Wrist Mount.....	156
Troubleshooting	158
Resetting the Device	158
Performing a Soft Reset.....	158
Performing a Hard Reset	158
WT6300	158
1-Slot Charging Cradle	160
2-Slot Device/RS6000 Charging Cradle	160
5-Slot Charge Only Cradle Troubleshooting.....	161
10-Slot Device/RS6000 Charge Only Cradle Troubleshooting.....	162
10-Slot Charge Only Cradle Troubleshooting.....	163
5-Slot Ethernet Cradle Troubleshooting	163
4-Slot Spare Battery Charger Troubleshooting	164
20-Slot Spare Battery Charger Troubleshooting	165
Technical Specifications.....	166
I/O Connector Pin-Outs	166
1-Slot USB Charging Cradle Technical Specifications	168
2-Slot Device/RS6000 Charging Cradle Technical Specifications	168
5-Slot Charge Only Cradle Technical Specifications.....	169
10-Slot Device/RS6000 Charge Only Cradle Technical Specifications	169
10-Slot Charge Only Cradle Technical Specifications	170
5-Slot Ethernet Cradle Technical Specifications	170
4-Slot Battery Charger Technical Specifications	171
20-Slot Battery Charger Technical Specifications	171
USB and Charging Cable Technical Specifications.....	172
Short Quick Disconnect Headset Adapter Cable Technical Specifications	172
Long Quick Disconnect Headset Adapter Cable Technical Specifications.....	172
Vibrator Cable Technical Specifications	173

About This Guide

This guide provides information about setting up and using the WT6300 wearable computer with the Android 10 operating system. Some screens shown in this guide may differ from the actual screens shown on the device.

Configurations

This guide covers the following configurations:

Table 1 Configurations

Configuration	Radios			Data Capture				Display	Keypad	Memory	OS		Sensors		Battery		
	802.11 abgn	Bluetooth 5.0	NFC	RS4000	RS5000	RS5100	RS6000	RS507X	3.2" WVGA Color	External Keypad	3G RAM/ 32GB Flash	Android AOSP V10	Android GMS V10	Accelerometer	Gyroscope	Standard	Extended
Standard																	
WT63B0-TS0QNERW	X	X	X	X	X	X	X	X	X		X		X	X	X	X	
WT63B0-TS0QNENA	X	X	X	X	X	X	X	X	X		X		X	X	X	X	
WT63B0-TX0QNERW	X	X	X	X	X	X	X	X	X		X		X	X	X		X
WT63B0-TX0QNENA	X	X	X	X	X	X	X	X	X		X		X	X	X		X
WT63B0-TS0ANECSN	X	X	X	X	X	X	X	X	X		X	X		X	X	X	
WT63B0-TS0QNETR	X	X	X	X	X	X	X	X	X		X		X	X	X	X	
WT63B0-TS0QNERU	X	X	X	X	X	X	X	X	X		X		X	X	X	X	
Premium																	
WT63B0-KS0QNERW	X	X	X	X	X	X	X	X	X	X	X		X	X	X	X	
WT63B0-KS0QNENA	X	X	X	X	X	X	X	X	X	X	X		X	X	X	X	
WT63B0-KX0QNERW	X	X	X	X	X	X	X	X	X	X	X		X	X	X		X
WT63B0-KX0QNENA	X	X	X	X	X	X	X	X	X	X	X		X	X	X		X
WT63B0-KS0ANECSN	X	X	X	X	X	X	X	X	X	X	X	X		X	X	X	

Notational Conventions

Notational conventions are used to highlight important information.

- **Bold** text is used to highlight the following:
 - Dialog box, window and screen names
 - Drop-down list and list box names
 - Check box and radio button names
 - Icons on a screen
 - Key names on a keypad
 - Button names on a screen.
- Bullets (•) indicate:
 - Action items
 - Lists of alternatives
 - Lists of required steps that are not necessarily sequential.
- Sequential lists (for example, those that describe step-by-step procedures) appear as numbered lists.

Icon Conventions

The following icons are used throughout the document. The icons and their associated meanings are described below.



NOTE: The text here indicates information that is supplemental for the user to know and that is not required to complete a task.



IMPORTANT: The text here indicates information that is important for the user to know.



CAUTION: If the precaution is not heeded, the user could receive minor or moderate injury.



WARNING: If danger is not avoided, the user CAN be seriously injured or killed.



DANGER: If danger is not avoided, the user WILL be seriously injured or killed.

Service Information

If you have a problem with your equipment, contact Customer Support for your region. Contact information is available at: zebra.com/support.

When contacting support, please have the following information available:

- Serial number of the unit (found on manufacturing label)
- Model number or product name (found on manufacturing label)
- Software type and version number

Customer Support responds to calls by email or telephone within the time limits set forth in support agreements.

If the problem cannot be solved by Customer Support, the user may need to return the equipment for servicing and will be given specific directions. We are not responsible for any damages incurred during shipment if the approved shipping container is not used. Shipping the units improperly can possibly void the warranty. Remove the microSD card from the device before shipping for service.

If the device was purchased from a business partner, contact that business partner for support.

Determining Software Versions

Before contacting Customer Support, determine the current software version on your device.

1. Swipe down from the Status bar with two fingers to open the Quick Access panel, and then touch .
2. Touch **Aboutphone**.
3. Scroll to view the following information:
 - **Battery information**
 - Emergency information
 - **SW components**
 - **Legal information**
 - **Model & hardware**
 - **Android version**
 - **Android security patch level**
 - **Kernel version**
 - **Build number**

Determining the Serial Number

Before contacting Customer Support, determine the serial number of your device.

Touch **About phone > Model & hardware > Serial number**.

Getting Started

This section provides information for getting the device up and running for the first time.

Unpacking

1. Carefully remove all protective material from the device and save the shipping container for later storage and shipping.
2. Verify that the following items were received:
 - Wearable computer
 - Lithium-ion battery
 - Regulatory Guide.
3. Inspect the equipment for damage. If any equipment is missing or damaged, contact the Global Customer Support center immediately.
4. Before using the device for the first time, remove the protective film that covers the screen.

Device Features

Figure 1 Front View

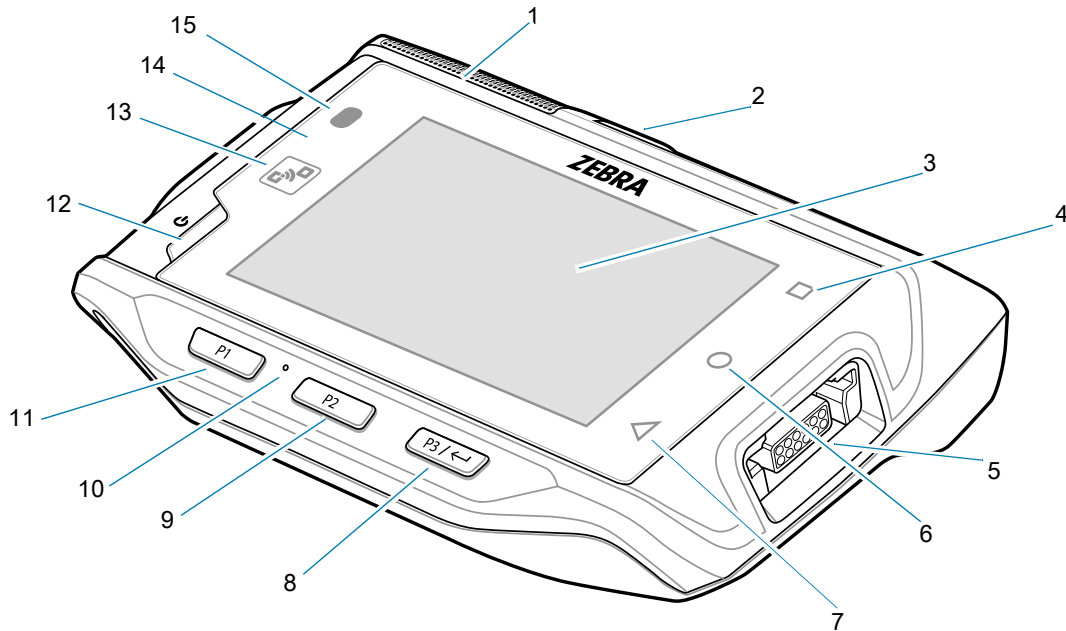

Number	Item	Function
1	Speaker	Provides audio output for video and music playback.
2	Battery ¹	Provides power to the device.
3	Display	Displays all information needed to operate the device.
4	Recent button	Displays recently open applications.
5	Right interface connector	Provides USB host and client communication, audio and device charging via cables and accessories.
6	Home button	Displays the Home screen.
7	Back button	Displays the previous screen.
8	P3 / Enter button	Use as the Enter button. If programmed as PTT, initiates Push-To-Talk communication.
9	P2 button	Increases volume.
10	Microphone	Use for communication on handset.
11	P1 button	Decreases volume.
12	Power button	Turns the display on and off. Press and hold to reset the device and power off.
13	NFC antenna	Provides communication with other NFC-enabled devices.
14	Ambient light sensor	Determines ambient light for controlling display backlight intensity.
15	Notification/Charge LED	Indicates battery charging status while charging with USB Charge cable and provide notifications from applications.

¹ Standard battery is shown.

Figure 2 Rear View

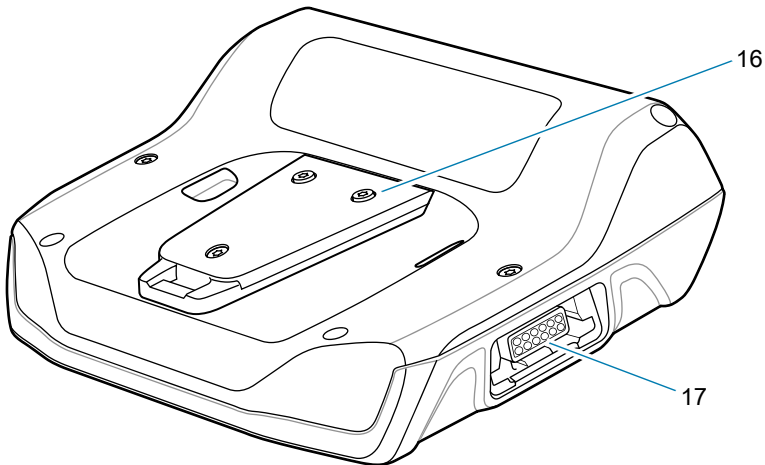

Number	Item	Function
16	Cleat	Provides alignment and secures the device to the wrist mount.
17	Left interface connector	Provides USB host and client communication, audio and device charging via cables and accessories.

Setting up the Device

To start using the device for the first time:

1. Install wrist mount (optional).
2. Install the battery.
3. Charge the device.
4. Power on the device.

Installing the Battery

To install the battery:

1. Insert the end of the battery into the battery well.

Figure 3 Standard Battery Installation

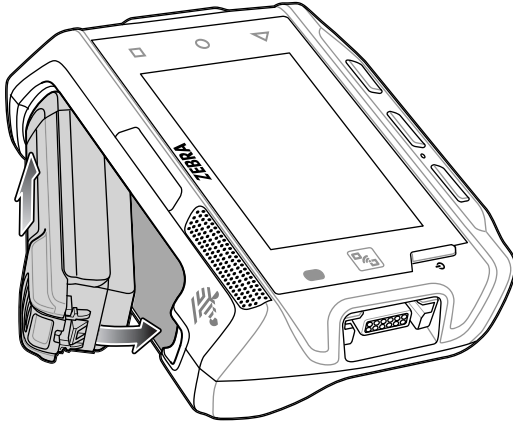
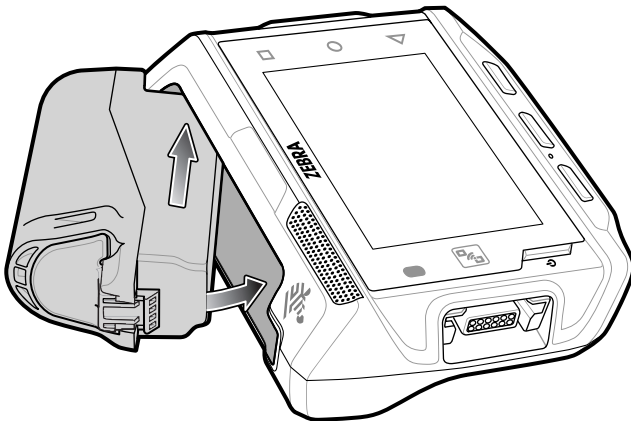

Figure 4 Extended Battery Installation



2. Press the battery down until it snaps into place.

Charging the Battery

Before using the device for the first time, charge the battery using a cable or a cradle with the appropriate power supply. For information about the accessories available for the device, see [Accessories](#).

The standard 3350 mAh battery fully charges in approximately four hours at room temperature. The extended 5000 mAh battery fully charges in approximately five hours and 30 minutes at room temperature.

To charge the main battery:

1. Connect the charging accessory to the appropriate power source.
2. Insert the device into a cradle or attach to a cable. The device turns on and begins charging. The Charging/Notification LED blinks amber while charging, then turns solid green when fully charged.

Charging Indicators

The following table describes the LED states and what they indicate.

Table 2 Charging/Notification LED Charging Indicators

State	Indication
Off	The device is not charging. The device is not inserted correctly in the cradle or connected to a power source. Charger/cradle is not powered.
Solid Amber	Healthy battery is charging.
Solid Green	Healthy battery charging is complete.
Fast Blinking Red (2 blinks/second)	Charging error, for example: - Temperature is too low or too high. - Charging has gone on too long without completion (typically eight hours).
Solid Red	Unhealthy battery is charging or fully charged.



NOTE: When trying to power on the device, a quick red blink of the Charging LED indicates that it does not have enough battery power to turn on. Charge the battery or replace it.

Charging Temperature

Charge batteries in temperatures from 0°C to 40°C (32°F to 104°F). The device or accessory always performs battery charging in a safe and intelligent manner. At higher temperatures (for example, approximately +37°C (+98°F)) the device or accessory may for small periods of time alternately enable and disable battery charging to keep the battery at acceptable temperatures. The device or accessory indicates when charging is disabled due to abnormal temperatures via its red blinking LED.

Installing the Wrist Mount

The wrist mount provides the mounting of the device on the forearm for hands-free applications. Refer to the Wrist Mount Installation Guide for information on the wrist mount.

Figure 5 Wrist Mount

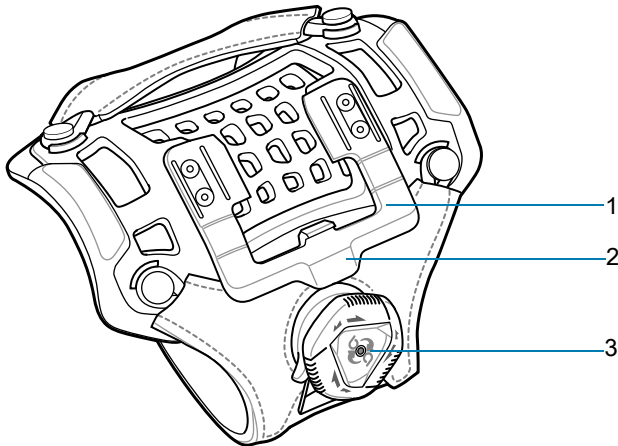

1	Mounting bracket
2	Release lever
3	Strap tighten dial

To install the wrist mount:

1. Slide the wrist mount onto arm.
2. Position the short strap on the forearm.
3. Push in the dial and turn the dial clockwise to tighten. If too tight, pull out the dial to loosen slightly.
4. Align the cleat on the back of the device with the mounting bracket on the wrist mount.

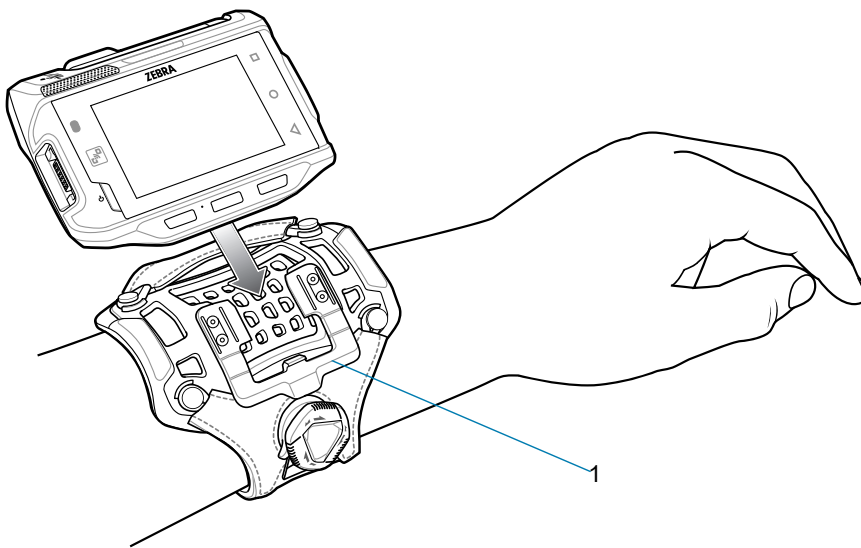

1	Mounting bracket
---	------------------

5. Slide the device onto the wrist mount until it clicks into place.
6. If necessary, use the dial to loosen and re-tighten the strap.

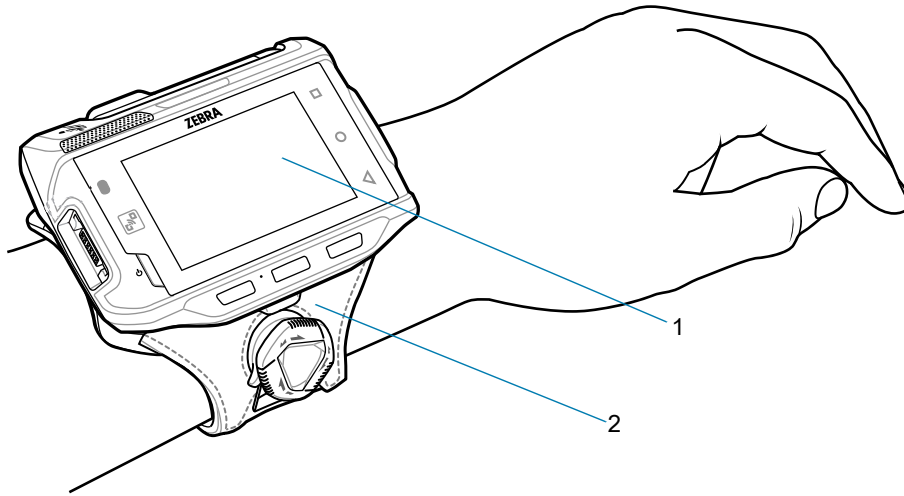

1	Device
2	Wrist mount

To remove the device from the wrist mount, press down on the release lever and slide the device out.

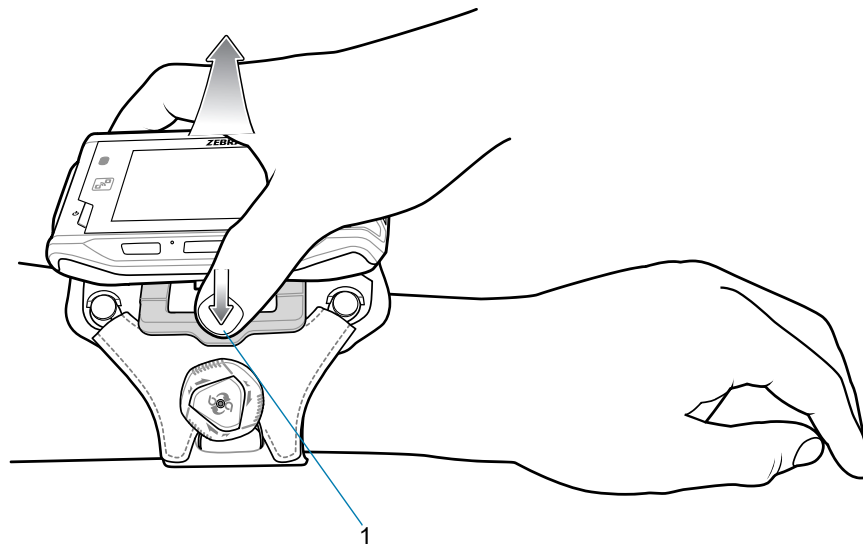

1	Release lever
---	---------------

Connecting a Scanner

The RS4000 scanner and the RS5000 and RS6000 imagers can be used with the device. See [RS4000 Scanner on page 125](#) and [RS5000 Imager on page 127](#) for procedures for connecting to the device. See [Pairing the RS507/X or RS6000 Hands-Free Imager on page 61](#).

Replacing the Battery

To remove the battery:

1. Press the Power button to place the device in suspend mode.
2. Using finger tip, press the battery release latch toward the end of the battery.

Figure 6 Press Release Latch Back on Standard Battery

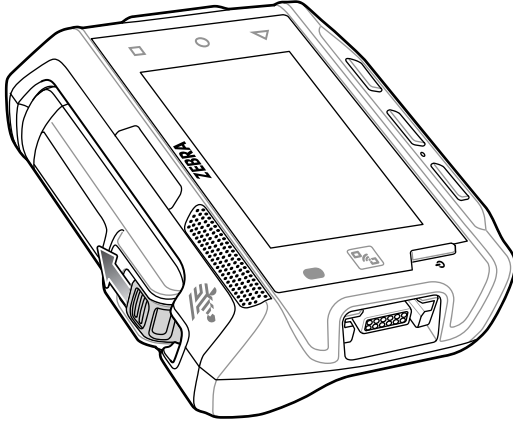
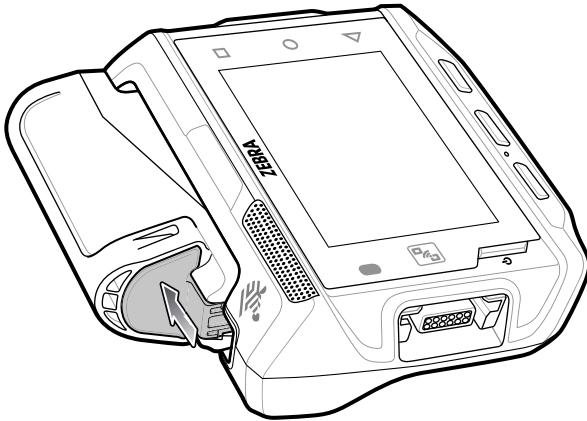

Figure 7 Press Release Latch Back on Extended Battery



3. Lift the battery out of the battery well.

Figure 8 Standard Battery Removal

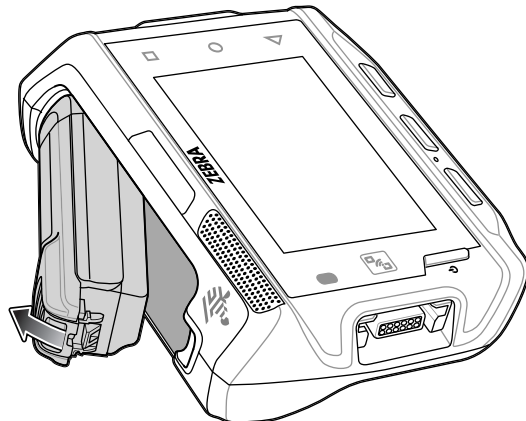
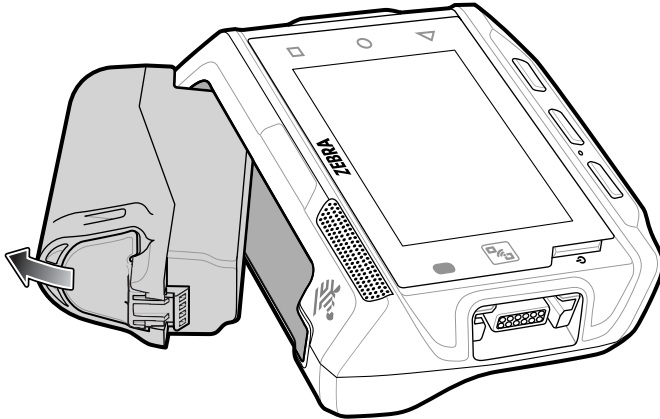

Figure 9 Extended Battery Removal



4. Insert the end of the battery into the battery well.

Figure 10 Standard Battery Installation

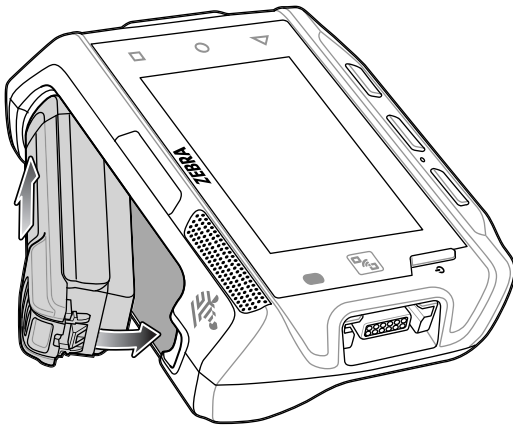
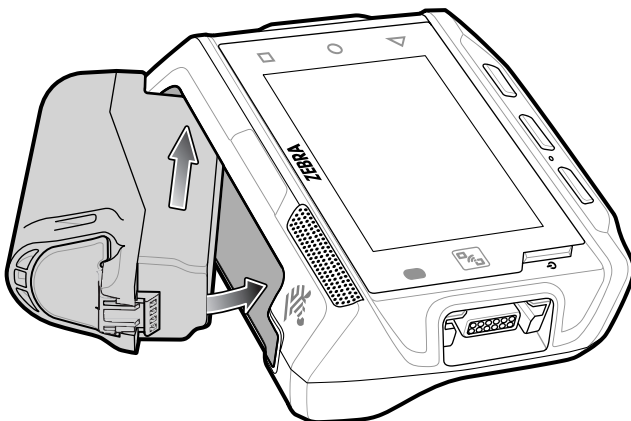

Figure 11 Extended Battery Installation



5. Press the battery down until it snaps into place.

Using the Device

Home Screen

Turn on the device to display the Home screen. Depending on how your system administrator configured your device, your Home screen may appear differently than the graphics in this section.

After a suspend or screen time-out, the Home screen displays with the lock slider. Touch the screen and slide up to unlock.

The Home screen provides four additional screens to place widgets and shortcuts. Swipe the screen left or right to view the additional screens.

Figure 12 Home Screen

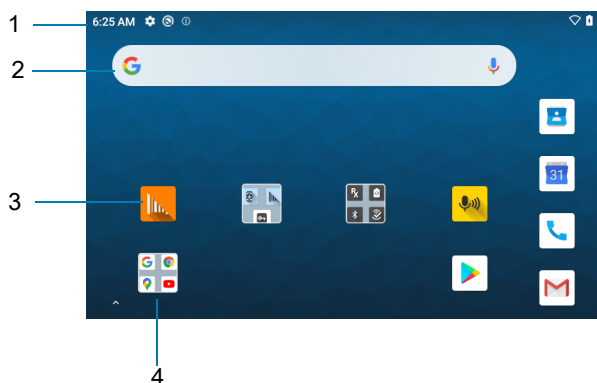

1	Status Bar	Displays the time, status icons (right side), and notification icons (left side). For more information see Notification Icons on page 24 and Managing Notifications on page 26 .
2	Widgets	Launches stand-alone apps that run on the Home screen.
3	Shortcut Icons	Opens apps installed on the device.
4	Folder	Contains apps.

Setting Home Screen Rotation

By default, the Home screen rotation is disabled.

1. Touch and hold anywhere on the Home screen until the options appear.
2. Touch **Home settings**.

3. Touch the **Allow Home screen rotation** switch.
4. Touch the Home button.
5. Rotate the device.

Status Bar

The Status bar displays the time, notification icons (left side), and status icons (right side).

If there are more notifications than can fit in the Status bar, a dot displays indicating that more notifications exist. Swipe down from the Status bar to open the Notification panel and view all notifications and status.

Figure 13 Notification and Status Icons



1	Notification Icons. See Notification Icons on page 24 .
2	Status Icons. See Status Icons on page 25 .







Notification Icons

Notification icons indicate app events and messages.

Table 3 Notification Icons

Icon	Description
	Main battery is low.
	More notifications are available for viewing.
	Data is syncing.
	Indicates an upcoming event. GMS devices only.
	Open Wi-Fi network is available.
	Audio is playing.
	Problem with sign-in or sync has occurred.
	Device is uploading data.
	Animated: the device is downloading data. Static: the download is complete.
	Device is connected to or disconnected from a virtual private network (VPN).
	Preparing internal storage by checking it for errors.
	USB debugging is enabled on the device.

Table 3 Notification Icons (Continued)

Icon	Description
	Wired headset with a boom module is connected to the device.
	Wired headset without a boom module is connected to the device.
	PTT Express Voice client status. See the PTT Express PTT Notification Icons for a complete list.
	Indicates the RxLogger app is running.
	Indicates the Bluetooth scanner is connected to the device.
	Indicates the ring scanner is connected to the device in HID mode.

Status Icons

Status icons display system information for the device.

Table 4 Status Icons





















Icon	Description
	Alarm is active.
	Main battery is fully charged.
	Main battery is partially drained.
	Main battery charge is low.
	Main battery charge is very low.
	Main battery is charging.
	All sounds, except media and alarms, are muted. Vibrate mode is active.
	Do Not Disturb mode active.
	Airplane Mode is active. All radios are turned off.
	Bluetooth is on.
	The device is connected to a Bluetooth device.
	Connected to a Wi-Fi network. Indicates the Wi-Fi version number.
	Not connected to a Wi-Fi network or no Wi-Fi signal.
	Connected to an Ethernet network.
	Indicates that the Orange key is locked.

Table 4 Status Icons (Continued)

Icon	Description
	Indicates that the Blue key is pressed.
	Indicates that the ALT key is pressed.
	Indicates that the CTRL key is pressed.
	Indicates that the Shift key is pressed.
	Indicates that the Shift key is locked.
	Indicates that the Blue Key and SHIFT key are pressed enabling CAPSLOCK.

Managing Notifications

Notification icons report the arrival of new messages, calendar events, alarms, and ongoing events. When a notification occurs, an icon appears in the Status bar with a brief description. See [Notification Icons on page 24](#) for a list of possible notification icons and their description.

- To view a list of all notifications, open the Notification panel by dragging the Status bar down from the top of the screen.

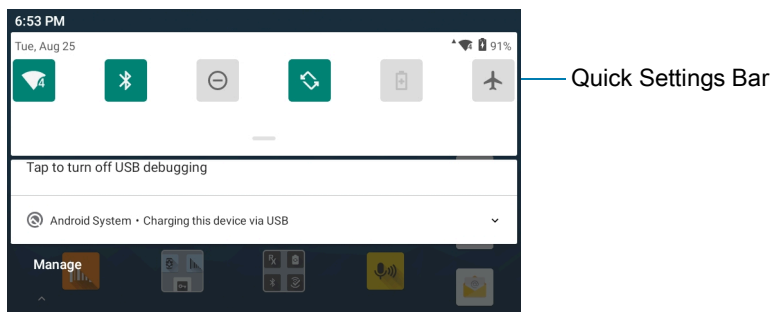

- To respond to a notification, open the Notification panel and then touch a notification. The Notification panel closes and the corresponding app opens.
- To manage recent or frequently used notifications, open the Notification panel and then touch **Manage notifications**. Touch the toggle switch next to an app to turn off all notifications, or touch an app for more notification options.
- To clear all notifications, open the Notification panel and then touch **CLEAR ALL**. All event-based notifications are removed. Ongoing notifications remain in the list.
- To close the Notification panel, swipe the Notification panel up.

Opening the Quick Access Panel

Use the Quick Access panel to access frequently used settings (for example, Airplane mode). To get to the Quick Access Panel:

- If the device is locked, swipe down once.
- If the device is unlocked, swipe down once with two fingers, or twice with one finger.

- If the Notification panel is open, swipe down from the Quick Settings bar.

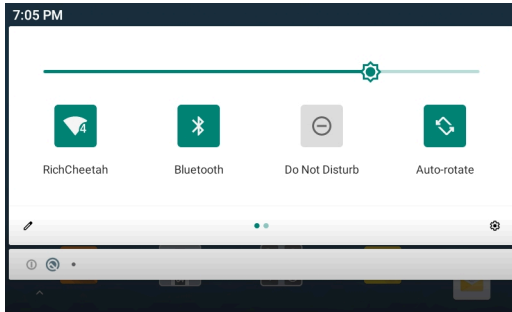

NOTE: Not all icons are pictured. Icons may vary.

Quick Access Panel Icons

- Display brightness - Use the slider to decrease or increase the brightness of the screen.
- Wi-Fi network - Turn Wi-Fi on or off. To open Wi-Fi settings, touch the Wi-Fi network name.
- Bluetooth settings - Turn Bluetooth on or off. To open Bluetooth settings, touch **Bluetooth**.
- Battery saver - Turn Battery saver mode on or off. When Battery saver mode is on the performance of the device is reduced to preserve battery power.
- Do not disturb - Control how and when to receive notifications.
- Airplane mode - Turn Airplane mode on or off. When Airplane mode is on the device does not connect to Wi-Fi or Bluetooth.
- Auto-rotate - Lock the device's orientation in portrait or landscape mode or set to automatically rotate.
- Screen Cast - Share phone content on Chromecast or a television with Google Cast built-in. Touch cast screen to display a list of devices, then touch a device to begin casting.

Editing Icons on the Quick Settings Bar

The first several setting tiles from the Quick Access panel become the Quick Settings bar.

Open the Quick Access panel and touch  to edit, add, or remove settings tiles.

Battery Management

Observe the recommended battery optimization tips for your device.

- Set the screen to turn off after a short period of non-use.
- Reduce screen brightness.
- Turn off all wireless radios when not in use.
- Turn off automatic syncing for Email, Calendar, Contacts, and other apps.
- Minimize use of apps that keep the device from suspending, for example, music and video apps.



NOTE: Before checking the battery charge level, remove the device from any AC power source (cradle or cable).

Checking Battery Status

- Open **Settings** and touch **About phone > Battery Information**.
- Or, swipe up from the bottom of the screen and touch  to open the **Battery Manager** app. See [Battery Manager on page 43](#).
- **Battery present status** indicates if the battery is present.
- **Battery level** lists the battery charge (as a percentage of fully charged).
- Swipe down with two fingers from the status bar to open the quick access panel.
- Battery percentage is displayed next to the battery icon.

Monitoring Battery Usage

The **Battery** screen provides battery charge details and power management options to extend battery life.

1. Go to **Settings**.
2. Touch **Battery**.

Display battery information and power management options for a specific app.

1. Go to **Settings**.
2. Touch **Apps & notifications**.
3. Touch an app.
4. Touch **Advanced > Battery**.

Different apps display different information. Some apps include buttons that open screens with settings to adjust power use.

Low Battery Notification

When the battery charge level drops below 15%, the device displays a notice to connect the device to power. The user should charge the battery using one of the charging accessories.

When the battery charge drops below 10%, the device displays a notice to connect the device to power. The user must charge the battery using one of the charging accessories.

When the battery charge drops below 5%, the device turns off. The user must charge the battery using one of the charging accessories.

Waking the Device

The device goes into Suspend mode when you press the Power button or after a period of inactivity (set in the Display settings window).

1. To wake the device from Suspend mode, press the Power, P1, P2, or P3/Enter button.

The Lock screen displays.

2. Swipe the screen up to unlock.
 - If the Pattern screen unlock feature is enabled, the Pattern screen appears instead of the Lock screen.
 - If the PIN or Password screen unlock feature is enabled, enter the PIN or password after unlocking the screen.



NOTE: If you enter the PIN, password, or pattern incorrectly five times, you must wait 30 seconds before trying again.

If you forget the PIN, password, or pattern contact your system administrator.

USB Communication

Connect the device to a host computer to transfer files between the device and the host computer.

When connecting the device to a host computer, follow the host computer's instructions for connecting and disconnecting USB devices, to avoid damaging or corrupting files. For information on USB communication accessories available for this device, see Accessories.

Transferring Files

Use Transfer files to copy files between the device and the host computer.

1. Connect the device to a host computer using a USB accessory.
2. On the device, pull down the Notification panel and touch **Charging this device via USB**.
By default, **No data transfer** is selected.
3. Touch **File Transfer**.



NOTE: After changing the setting to **File Transfer**, and then disconnect the USB cable, the setting reverts back to **No data transfer**. If the USB cable is reconnected, select **File Transfer** again.

4. On the host computer, open a file explorer application.
5. Locate the **device** as a portable device.
6. Open the **Internal storage** folder.
7. Copy files to and from the device or delete files as required.

Transferring Photos

Use **PTP** to copy photos from the device to the host computer.

1. Connect the device to a host computer using a USB accessory.
2. On the device, pull down the Notification panel and touch **Charging this device via USB**.
3. Touch Transfer photos **PTP**.
4. On the host computer, open a file explorer application.
5. Open the **Internal storage** folder.
6. Copy or delete photos as required.

Disconnect from the Host Computer



To disconnect the device from the host computer:

1. On the host computer, unmount the device.
2. Remove the device from the USB accessory.

Settings

Accessing Settings

There are multiple ways to access settings on a device.

- Swipe down with two fingers from the top of the Home screen to open the Quick Access panel and touch .
- Double-swipe down from the top of the Home screen to open the Quick Access panel and touch .
- Swipe up from the bottom of the Home screen to open APPS and touch  **Settings**.

Display Settings

Use Display settings to change the screen brightness, enable night light, change the background image, enable screen rotation, set sleep time, and change font size.

Setting the Screen Brightness Manually

Manually set the screen brightness using the touchscreen.

1. Swipe down with two fingers from the Status bar to open the Quick Access panel.
2. Slide the icon to adjust the screen brightness level.

Setting the Screen Brightness Automatically

Automatically adjust the screen brightness using the built-in light sensor.

1. Go to **Settings**.
2. Touch **Display**.
3. If disabled, touch **Adaptive brightness** to automatically adjust the brightness.
By default, **Adaptive brightness** is enabled. Toggle the switch to disable.
4. Touch the Home button.

Setting Night Light

The Night Light setting tints the screen amber, making the screen easier to look at in low light.

1. Go to **Settings**.
2. Touch **Display**.

3. Touch **Night Light**.
4. Touch **Schedule**.
5. Select one of the schedule values:
 - None (default)
 - Turns on at custom time
 - Turns on from sunset to sunrise.
6. By default, **Night Light** is disabled. Touch **TURN ON NOW** to enable.
7. Adjust the tint using the **Intensity** slider.
8. Touch the Home button.

Setting Screen Rotation

By default, screen rotation is enabled.

1. Go to **Settings**.
2. Touch **Display > Advanced**.
3. Touch **Auto-rotate screen**.



NOTE: To change the Home screen rotation, see [Setting Home Screen Rotation on page 23](#).

4. Touch the Home button.

Setting Screen Timeout

Set the screen sleep time.

1. Go to **Settings**.
2. Touch **Display > Advanced > Screen timeout**.
3. Select one of the sleep values.
 - **15 seconds**
 - **30 seconds**
 - **1 minute** (default)
 - **2 minutes**
 - **5 minutes**
 - **10 minutes**
 - **30 minutes**
4. Touch the Home button.

Lock Screen Display

The lock screen display setting wakes the screen when notifications are received.

1. Go to **Settings**.
2. Touch **Display > Advanced**.

3. Touch **Lock screen display**.
4. In the **When to show** section, enable or disable an option using the switch.
5. Touch the Home button.

Setting Font Size

Set the size of the font in system apps.

1. Go to **Settings**.
2. Touch **Display > Advanced**.
3. Touch **Font size**.
4. Select one of the font size values.
 - Small
 - Default
 - Large
 - Largest.
5. Touch the Home button.

Setting the Date and Time

You are only required to set the time zone or set the date and time if the wireless LAN does not support Network Time Protocol (NTP).



1. Go to **Settings**.
2. Touch **System > Date & time**.
3. Touch **Use network-provided time** to disable automatic date and time synchronization.
4. Touch **Date**.
5. In the calendar, set today's date.
6. Touch **OK**.
7. Touch **Time**.
8. Touch the green circle, drag to the current hour and then release.
9. Touch the green circle, drag to the current minute and then release.
10. Touch **AM** or **PM**.
11. Touch **OK**.
12. Touch **Time zone**.
13. Touch **Update interval** to select interval to synchronize the system time from the network.
14. In **TIME FORMAT**, choose either **Use local default** or **Use 24-hour format**.
15. Touch **Use 24-hour format**.
16. Touch the Home button.

General Sound Setting

Use the **Sound** settings to configure media and alarm volumes.

1. Go to **Settings**.
2. Touch **Sound**.
3. Touch an option to set sounds.

Sound Options

- **Zebra volume controls**
 - **Ring volume** - Controls the ringtone volume.
 - **Media volume** - Controls the music, games, and media volume.
 - **Alarm volume** - Controls the alarm clock volume.
 - **Notifications volume** - Controls the notification volume.
 - **In call volume** - Controls the volume during a call.
 - **Scanner volume** - Controls the scanner volume.
- **Volume presets**
 -  - Mutes the ring, notifications, and scanner so that the device does not make sounds or vibrate.
 -  - All sounds except media and alarms are silenced and vibrate mode is active.
 -  - Enables all sounds at the user defined levels.
- **Shortcut to prevent ringing** - Turn on the switch to make the device vibrate when a call is received (default – disabled).
- **Do Not Disturb** - Mutes some or all sounds and vibrations.
- **Default notification sound** - Select a sound to play for all system notifications.
- **Default alarm sound** - Select a sound to play for alarms.
- **Other sounds and vibrations**
 - **Screen locking sounds** - Play a sound when locking and unlocking the screen (default – enabled).
 - **Charging sounds and vibration** - Plays a sound and vibrates when power is applied to the device (default - enabled).
 - **Touch sounds** - Play a sound when making screen selections (default – enabled).
 - **Touch vibration** - Vibrate the device when making screen selections (default – disabled).
- **Wireless Emergency alerts** - Touch to configure emergency broadcast settings and notifications.

Setting Wake-Up Sources

- By default the device wakes from suspend mode when the user presses the **Power** button.P1
 - P2
 - P3
1. Touch a checkbox. A check appears in the checkbox.
 2. Touch the Home button.

Remapping a Button

Buttons on the device can be programmed to perform different functions or as shortcuts to installed apps. For a list of key names and descriptions, refer to: techdocs.zebra.com.

1. Go to **Settings**.
2. Touch **Key Programmer**. A list of programmable buttons displays.
3. Select the button to remap.
4. Touch the **BUTTON REMAPPING**, the **SHORTCUT**, or the **TRIGGERS** tabs to list the available functions, applications, and triggers.
5. Touch a function or application shortcut to map to the button.



NOTE: If you select an application shortcut, the application icon appears next to the button on the Key Programmer screen.

6. Touch the Home button.

Remappable Keys

Figure 14 Key Positions

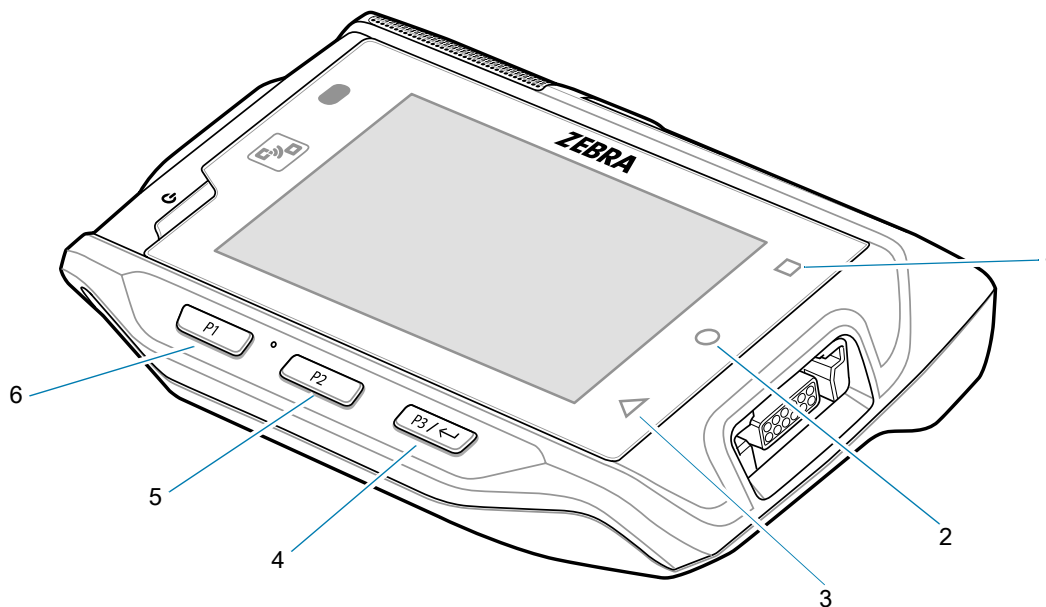

Number	Button	Description
1	RECENT	Recent Button
2	HOME	Home Button
3	BACK	Back Button
4	P3	Enter Button
5	P2	Volume Up Button
6	P1	Volume Down Button

Keyboards

The device provides multiple keyboard options.

- Android Keyboard - AOSP devices only
- Enterprise Keyboard



NOTE: By default the Enterprise and Virtual Keyboards are disabled.



Keyboard Configuration

Enabling Keyboards

1. Go to **Settings**.
2. Touch **System > Languages & input > Virtual keyboard > Manage keyboards**.
3. Touch a keyboard to enable.

To enable a virtual keyboard like Gboard or Enterprise keyboard:

Switching Between Keyboards

- To switch between keyboards, touch in a text box to display the current keyboard.
 - On the Gboard keyboard, touch and hold  (GMS devices only).
 - On the Android keyboard, touch and hold  (AOSP devices only).

Using the Android and Gboard Keyboards

Use the Android or Gboard keyboards to enter text in a text field.

To configure the keyboard settings, touch and hold **,** (comma) and then select **Android keyboard settings**.

Edit Text

Edit entered text and use menu commands to cut, copy, and paste text within or across apps. Some apps do not support editing some or all of the text they display; others may offer their own way to select text.

Entering Numbers, Symbols, and Special Characters

1. Enter numbers and symbols.
 - Touch and hold one of the top-row keys until a menu appears then select a number or special character.
 - Touch the Shift key once for a single capital letter. Touch the Shift key twice to lock in uppercase. Touch the Shift key a third time to unlock Capslock.
 - Touch **?123** to switch to the numbers and symbols keyboard.
 - Touch the **=\<** key on the numbers and symbols keyboard to view additional symbols.
2. Enter special characters.
 - Touch and hold a number or symbol key to open a menu of additional symbols. A larger version of the key displays briefly over the keyboard.

Keypad

The alphanumeric keypad accessory contains scroll keys and function keys. The keypad is color-coded to indicate the alternate function keys (blue, orange and gray).



NOTE: The keypad functions can be changed by an application, so the wearable terminal's keypad may not function exactly as described.

Figure 15 Keypad

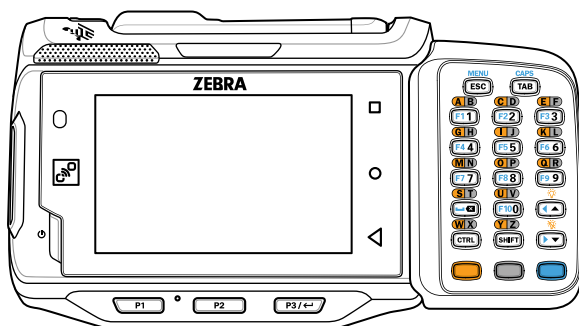





Table 5 Alphanumeric Keypad Descriptions

Key	Description
Orange	Press and release the Orange key to activate alphabetic characters (shown on the keypad in orange). The orange icon appears in the Status bar.
Gray	Press and release the Gray key to activate alphabetic characters (shown on the keypad in gray). The gray icon appears in the Status bar.
Blue	Press and release the Blue key to activate the keypad alternate functions (shown on the keypad in blue). The blue icon appears in the Status bar.
Scroll Keys	Moves up or down from one item to another or increases/decreases specified values. Moves left or right from one item to another when used with the Blue key. For each left or right scroll, the Blue key must be pressed first.
ESC	Exits the current operation.
Alphanumeric	In default state, produces the numeric value on the key. In Left Alpha state, produces the lower case alphabetic characters in the orange area. In Right Alpha state, produces the lower case alphabetic characters in the gray area. When the CAPS key is pressed in the Alpha state, the upper case alphabetic characters on the key are produced. For example, press and release the Orange key, press and release the CAPS key and then press the 4 key once to produce the letter 'G'.
CTRL (Control)	Press and release the CTRL key to activate the keypad alternate CTRL functions. The CTRL icon appears in the Status bar. Press the Blue key followed by the CTRL key to activate the keypad alternate ALT functions. The ALT icon appears in the Status bar.
SHIFT	Press and release the SHIFT key to activate the keypad alternate SHIFT functions. The arrow icon appears in the Status bar.

Table 5 Alphanumeric Keypad Descriptions (Continued)

Key	Description
ENTER	Executes a selected item or function.
TAB	Move the focus to the next field in a window.
MENU	Press and release Blue key, then press and release the MENU key to display the menu on the current screen.
CAPS	Press and release Blue key, then press and release the CAPS key to activate upper case alphabetic characters.
	Backspace function.
	Space function when used with the Blue key.
	Enables the backlight when used with the Orange key.
	Disables the backlight when used with the Orange key.

The keypad is color-coded to indicate the alternate function key (blue) values and the alternate ALPHA key (orange) values. The following table describes the special character generation.

Table 6 Special Character Generation Map

Special Character	Keypad
! (exclamation point)	Shift - 1
@ (at sign)	Shift - 2
# (Pound sign)	Shift - 3
\$ (dollar sign)	Shift - 4
% (percent sign)	Shift - 5
^ (carat)	Shift - 6
& (ampersand)	Shift - 7
* (asterisk)	Shift - 8

Table 6 Special Character Generation Map (Continued)

Special Character	Keypad
((open parenthesis)	Shift - 9
) (close parenthesis)	Shift - 0

Language Usage

Use the **Language & input** settings to change the device's language, including words added to the dictionary.

Changing the Language Setting

1. Go to **Settings**.
2. Touch **System > Languages & input**.
3. Touch **Languages**. A list of available languages displays.
4. If the desired language is not listed, touch **Add a language** and select a language from the list.
5. Touch and hold  to the right of the desired language, then drag it to the top of the list.
6. The operating system text changes to the selected language.

Adding Words to the Dictionary

1. Go to **Settings**.
2. Touch **System > Languages & input > Advanced > Personal dictionary**.
3. If prompted, select the language where this word or phrase is stored.
4. Touch **+** to add a new word or phrase to the dictionary.
5. Enter the word or phrase.
6. In the **Shortcut** text box, enter a shortcut for the word or phrase.
7. Touch the Home button.

Notifications

Setting App Notifications

To set notification settings for a specific app:

1. Go to **Settings**.
2. Touch **Apps & notifications > SEE ALL XX APPS**. The **App info** screen displays.
3. Select an app.
4. Touch **Notifications**.

Options vary depending on the app selected.

5. Select an available option:

Show notifications - Select to turn all notifications from this app on (default) or off.

Touch a notification category to display additional options.

- **Alerting** - Allow notifications from this app to make sound.
 - **Pop on screen** - Allow notifications from this app to pop notifications on the screen.
- **Silent** - Do not allow notifications from this app to make sound.
 - **Minimize** - In the Notification panel, collapse notifications to one line.
- **Advanced** - Touch for additional options.
 - **Sound** - Select a sound to play for notifications from this app.
 - **Blink light** - Allow notifications from this app the light the Notification LED blue.
 - **Show notification dot** - Allow notifications from this app to add a notification dot to the app icon.
 - **Override Do Not Disturb** - Allow these notifications to interrupt when Do Not Disturb is enabled.

Advanced

- **Allow notification dot** - Do not allow this app to add a notification dot to the app icon.
- **Additional settings in the app** - Open the app settings.

Viewing Notification Settings for All Apps

To view the notification settings for all apps:

1. Go to **Settings**.
2. Touch **Apps & Notifications**.
3. Scroll down to **Notifications** to view how many apps have notifications turned off.
4. To set or view notifications settings for a specific app, see Setting App Notifications.

Controlling Lock Screen Notifications

To control whether notifications can be seen when the device is locked:

1. Go to **Settings**.
2. Touch **Apps & notifications > Notifications**.
3. Touch **Notifications on lockscreen** and select one of the following:
 - **Show alerting and silent notifications** (default)
 - **Show alerting notifications only**
 - **Don't show notifications**.

Blink Light

The Notification LED lights blue when an app, such as email and VoIP, generates a programmable notification or to indicate when the device is connected to a Bluetooth device. By default, LED notifications are enabled.

To change the notification setting:

1. Go to **Settings**.
2. Touch **Apps & notifications > Notifications > Advanced**.

3. Touch **Blink light** to toggle the notification on or off.

Applications

The **APPS** screen displays icons for all installed apps. See Application Deployment for information on installing and uninstalling apps. For information on standard Android apps, go to the Google Play [Apps store](#).

The following table describes the apps installed on the device.

Table 7 Apps



















Icon	Description
	Battery Manager - Displays battery information, including charge level, status, health and wear level.
	Bluetooth Pairing Utility – Use to pair a Zebra Bluetooth scanner with the device by scanning a barcode.
	Calculator - Provides the basic and scientific arithmetic functions.
	Calendar - Use to manage events and appointments.
	Clock - Use to schedule alarms for appointments or as a wake-up.
	Contacts - Use to manage contact information.
	DataWedge - Enables data capture using the imager. For more information, see DataWedge Demonstration on page 45 .
	DWDemo - Provides a way to demonstrate the data capture features using the imager. For more information, see DataWedge Demonstration on page 45 .
	Email - Use to send and receive email.

Table 7 Apps (Continued)

Icon	Description
	Files - Organize and manage files on the device.
	Gallery - Use to view photos stored on the .
	Music - Play music stored on the microSD card or internal storage. AOSP only.
	Phone - Use to dial a phone number when used with some Voice over IP (VoIP) clients (VoIP telephony ready only).
	PTT Express - Use to launch PTT Express client for VoIP communication.
	RxLogger - Use to diagnose device and app issues. For more information, see RxLogger on page 49 .
	RxLogger Utility - Use to view, backup, and archive RxLogger data.
	Settings - Use to configure the device.
	Sound Recorder - Use to record audio. For more information, see Sound Recorder on page 50 .
	Worry Free Wifi Analyzer - A diagnostic intelligent app. Use to diagnose surrounding area and display network stats, such as coverage hole detection, or AP in vicinity. Refer to the Worry Free Wi-Fi Analyzer Administrator Guide for Android.

Accessing Apps

All apps installed on the device are accessed using the **APPS** window.

1. On the Home screen, swipe up from the bottom of the screen.
2. Slide the **APPS** window up or down to view more app icons.
3. Touch an icon to open the app.

Switching Between Recent Apps

Use the Recent button to switch between recently used apps.

1. Touch Recent button.
A window appears on the screen with icons of recently used apps.

2. Slide the apps displayed up and down to view all recently used apps.
3. Swipe left or right to remove app from the list and force close the app.
4. Touch an icon to open an app or touch Back button to return to the current screen.

Battery Manager

The **Battery Manager** provides detailed information about the battery and battery swap procedures on supported devices.



Opening Battery Manager

To open the Battery Manager app, swipe up from the bottom of the Home screen, and then touch .

Battery Manager Information

The Battery Manager displays detailed information about battery charging, health, and status.

Table 8 Battery Icon Description

Battery Icon	Description
	Battery charge level is between 85% and 100%.
	Battery charge level is between 19% and 84%.
	Battery charge level is between 0% and 18%.









- **Level** - The current battery charge level as a percentage. Displays -% when level is unknown.
- **Wear** - The health of the battery in graphical form. When the wear level exceeds 80%, the bar color changes to red.
- **Health** - The health of the battery. If a critical error occurs,  appears. Touch to view the error description.
 - **Decommission** - The battery is past its useful life and should be replaced. See system administrator.
 - **Good** - The battery is good.
 - **Charge error** - An error occurred while charging. See system administrator.
 - **Over Current** - An over-current condition occurred. See system administrator.
 - **Dead** - The battery has no charge. Replace the battery.
 - **Over Voltage** - An over-voltage condition occurred. See system administrator.
 - **Below Temperature** - The battery temperature is below the operating temperature. See system administrator.
 - **Failure Detected** - A failure has been detected in the battery. See system administrator.

- **Unknown** - See system administrator.
- **Charge Status**
 - **Charging-AC** - The device is connected to AC power and charging.
 - **Charging-USB** - The device is connected to a host computer with a USB cable and charging.
 - **Discharging** - The battery is discharging.
 - **Full** - That the battery is fully charged.
 - **Unknown** - The battery status is unknown.
- **Time until Full** - The amount of time until the battery is fully charged.
- **Time since charging** - The amount of time since the device began charging.
- **Time until empty** - The amount of time until the battery is empty.
- **Advanced info** - Touch to view additional battery information.
 - **Battery present status - Indicates that the battery is present.**
 - **Battery level** - The battery charge level as a percentage of scale.
 - **Battery scale** - The battery scale level used to determine battery level (100).
 - **Battery voltage** - The current battery voltage in millivolts.
 - **Battery temperature** - The current battery temperature in degrees Centigrade.
 - **Battery technology** - The type of battery.
 - **Battery current** - The average current into or out of the battery over the last second in mAh.
 - **Battery manufacture date** - The date of manufacture.
 - **Battery serial number** - The battery serial number. The number matches the serial number printed on the battery label.
 - **Battery part number** - The battery part number.
 - **Battery decommission status** - Indicates if the battery is past its life span.
 - **Battery Good** - The battery is in good health.
 - **Decommissioned Battery** - The battery is past its useful life and should be replaced.
 - **Base cumulative charge** - Cumulative charge using Zebra charging equipment only.
 - **Battery present capacity** - Maximum amount of charge that could be pulled from the battery under the present discharge conditions if the battery were fully charged.
 - **Battery health percentage** - With a range from **0** to **100**, this is the ratio of “present_capacity” to “design_capacity” at a discharge rate of “design_capacity”.
 - **% decommission threshold** - The default % decommission threshold for a gifted battery as 80%.
 - **Battery present charge** - Amount of usable charge remaining in the battery at present under the current discharge conditions.
 - **Battery total cumulative charge** - The total accumulated charge in all chargers.
 - **Battery time since first use** - The time passed since the battery was placed in a Zebra terminal for the first time.
 - **Battery error status** - The error status of the battery.
 - **App version** - The application version number.

DataWedge Demonstration

Use **DataWedge Demonstration** to demonstrate data capture functionality. To configure DataWedge, refer to techdocs.zebra.com/datawedge/.

Table 9 DataWedge Demonstration Icons

	Icon	Description
Illumination		Imager illumination is on. Touch to turn illumination off.
		Imager illumination is off. Touch to turn illumination on.
Data Capture		An RS4000 laser scanner or RS5000 imager is connected.
		An RS4000 laser scanner or RS5000 imager is not connected.
		An RS507 or RS6000 Bluetooth imager is connected.
		An RS507 or RS6000 Bluetooth imager is not connected.
Scan Mode		Imager is in picklist mode. Touch to change to normal scan mode.
		Imager is in normal scan mode. Touch to change to picklist mode.
Menu		Opens a menu to view the application information or to set the application DataWedge profile.

Scanner Selection

To select a scanner, touch  > **Settings** > **Scanner selection**.

See the Data Capture section for more information.

Press the programmable button or touch the yellow scan button to capture data. The data appears in the text field below the yellow button.

PTT Express Voice Client



NOTE: Requires a PTT Express License. Not available in all countries.

PTT Express Voice Client enables Push-To-Talk (PTT) communication between disparate enterprise devices. Leveraging existing Wireless Local Area Network (WLAN) infrastructure, PTT Express delivers simple PTT communication without requiring a voice communication server.

- **Group Call:** Press and hold the PTT (Talk) button to start communicating with other voice client users.
- **Private Response:** Double-press the PTT button to respond to the originator of the last broadcast or to make a Private Response.

PTT Express User Interface

Figure 16 PTT Express Default User Interface

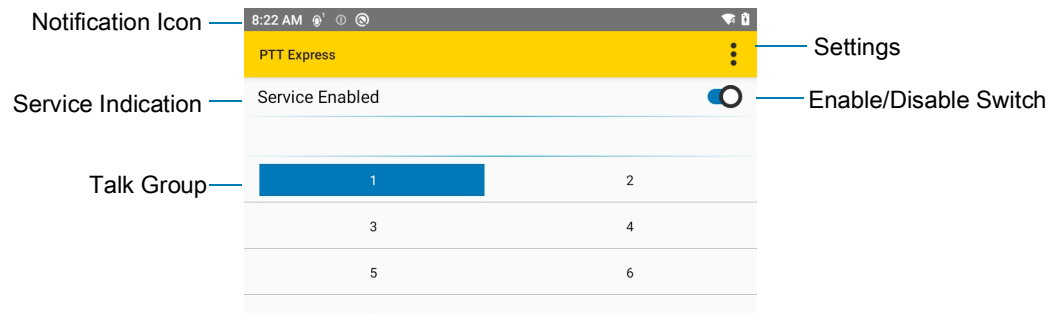

Table 10 PTT Express Default User Interface Descriptions

Item	Description
Notification Icon	Indicates the current state of the PTT Express client.
Service Indication	Indicates the status of the PTT Express client. Options: Service Enabled , Service Disabled or Service Unavailable .
Talk Groups	Lists all 32 Talk Groups available for PTT communication.
Settings	Opens the PTT Express Settings screen.
Enable/Disable Switch	Turns the PTT service on and off.

PTT Audible Indicators

The following tones provide helpful cues when using the voice client.







- **Talk Tone:** Double chirp. Plays when the Talk button is depressed. This is a prompt for you to start talking.
- **Access Tone:** Single beep. Plays when another user just finished a broadcast or response. You can now initiate a Group Broadcast or Private Response.
- **Busy Tone:** Continuous tone. Plays when the Talk button is depressed and another user is already communicating on the same talkgroup. Plays after the maximum allowed talk time is reached (60 seconds).

- **Network Tone:**
 - Three increasing pitch beeps. Plays when PTT Express acquires the WLAN connection and the service is enabled.
 - Three decreasing pitch beeps. Plays when PTT Express loses the WLAN connection or the service is disabled.

PTT Notification Icons

Notification icons indicate the current state of the PTT Express Voice client.

Table 11 PTT Express Icon Descriptions

Status Icon	Description
	The PTT Express Voice client is disabled.
	The PTT Express Voice client is enabled but not connected to a WLAN.
	The PTT Express Voice client is enabled, connected to a WLAN, and listening on the Talk Group indicated by the number next to the icon.
	The PTT Express Voice client is enabled, connected to a WLAN, and communicating on the Talk Group indicated by the number next to the icon.
	The PTT Express Voice client is enabled, connected to a WLAN, and in a private response.
	The PTT Express Voice client is enabled and muted.
	The PTT Express Voice client is enabled but it is not able to communicate due to a VoIP telephony call in progress.

Enabling PTT Communication

1. Swipe up from the bottom of the Home screen and touch .
2. Slide the **Enable/Disable Switch** to the **ON** position. The button changes to **ON**.

Selecting a Talk Group

One of 32 Talk Groups can be selected by PTT Express users. However, only one talk group may be enabled at a time on the device. Touch one of the 32 Talk Groups. The selected Talk Group is highlighted.

PTT Communication



NOTE: This section describes the default PTT Express client configuration. Refer to the PTT Express V1.2 User Guide for detailed information on using the client.

PTT communication may be established as a Group Call.

Figure 17 PTT Button

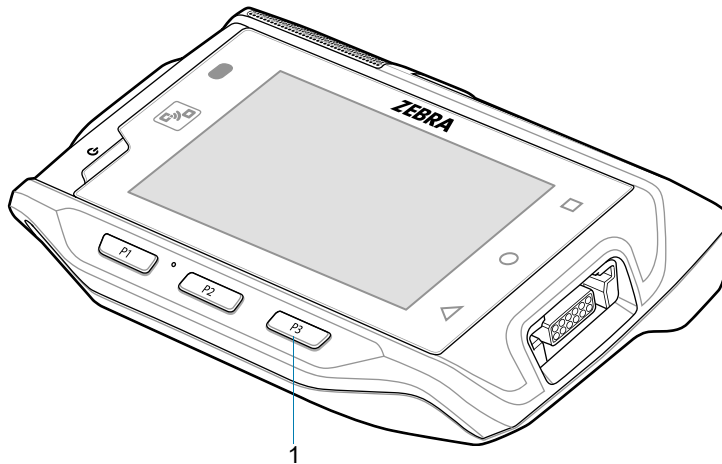

1	PTT button
---	------------

Creating a Group Call

1. Press and hold the PTT button (or the Talk button on the headset) and listen for the talk tone.
If you hear a busy tone, release the button and wait a moment before making another attempt. Ensure that PTT Express and the WLAN are enabled.
2. Start talking after hearing the talk tone.



NOTE: Holding the button for more than 60 seconds (default) drops the call, allowing others to make Group calls. Release the button when finished talking to allow others to make calls.

Responding with a Private Response

The Private Response can only be initiated once a Group Call has been established. The initial Private Response is made to the originator of the Group Call.

1. Wait for an access tone.
2. Within 10 seconds, double-press the PTT button, and listen for the talk tone.
3. If you hear a busy tone, release the button and wait a moment before making another attempt. Ensure that PTT Express and the WLAN are enabled.
4. Start talking after the talk tone plays.
5. Release the button when finished talking.

Disabling PTT Communication

1. Swipe up from the bottom of the Home screen and touch .
2. Slide the **Enable/Disable Switch** to the **OFF** position. The button changes to **OFF**.
3. Touch the Home button.

RxLogger

RxLogger is a comprehensive diagnostic tool that provides application and system metrics, and diagnoses device and application issues. RxLogger logs the following information: CPU load, memory load, memory snapshots, battery consumption, power states, wireless logging, TCP dumps, Bluetooth logging, logcat, FTP push/pull, ANR dumps, etc. All generated logs and files are saved onto flash storage on the device (internal or external).

RxLogger Configuration

RxLogger is built with an extensible plug-in architecture and comes packaged with a number of plug-ins already built-in. For information on configuring RxLogger, refer to techdocs.zebra.com/rxlogger/.

To open the configuration screen, from the RxLogger home screen touch **Settings**.

Configuration File

RxLogger configuration can be set using an XML file. The `config.xml` configuration file is located in the `RxLogger\config` folder. Copy the file from the device to a host computer using a USB connection. Edit the configuration file and then replace the XML file on the device. There is no need to stop and restart the RxLogger service since the file change is automatically detected.

Enabling Logging

To enable logging:

1. Swipe the screen up and select .
2. Touch **Start**.
3. Touch the Home button.

Disabling Logging

To disable logging:

1. Swipe the screen up and select .
2. Touch **Stop**.
3. Touch the Home button.

Extracting Log Files

1. Connect the device to a host computer using an USB connection.
2. Using a file explorer, navigate to the `RxLogger` folder.
3. Copy the file from the device to the host computer.
4. Disconnect the device from the host computer.

Backing Up

RxLogger Utility allows the user to make a zip file of the `RxLogger` folder in the device, which by default contains all the RxLogger logs stored in the device.

To save the backup data, touch  > **BackupNow**.

RxLogger Utility

RxLogger Utility is a data monitoring application for viewing logs in the device while RxLogger is running. Logs and RxLogger Utility features are accessed using Main Chat Head.

Initiating the Main Chat Head

To initiate the Main Chat Head:

1. Open **RxLogger**.
2. Touch  > **Toggle Chat Head**. The Main Chat Head icon appears on the screen.
3. Touch and drag the Main Chat head icon to move it around the screen.

Removing the Main Chat Head

To remove the Main Chat Head icon:

1. Touch and drag the icon. A circle with an X appears.
2. Move the icon over the circle and then release.

Viewing Logs

To view logs:

1. Touch the Main Chat Head icon. The RxLogger Utility screen appears.
2. Touch a log to open it. The user can open many logs with each displaying a new sub Chat Head.
3. If necessary, scroll left or right to view additional Sub Chat Head icons.
4. Touch a Sub Chat Head to display the log contents.

Removing a Sub Chat Head Icon

To remove a sub chat Head icon, press and hold the icon until it disappears.

Backing Up In Overlay View

RxLogger Utility allows the user to make a zip file of the **RxLogger** folder in the device, which by default contains all the RxLogger logs stored in the device.

The Backup icon is always available in Overlay View.

1. Touch . The Backup dialog box appears.
2. Touch **Yes** to create the back up.

Sound Recorder

Use **Sound Recorder** to record audio messages.

Recordings are saved on the microSD card (if installed) or the internal storage, and are available in the Music application (AOSP devices) or the Play Music application (GMS devices).

Touch  to open options menu.

- **File type** - Select the file type for the recording file.
 - **AMR**
 - **3GPP**
 - **AAC**
 - **WAV**
 - **AMR-WB**
 - **AMR-WB-3GPP.**
- **Storage location** - Select the location for the recording file.
 - **Phone storage**

Data Capture

Introduction

The device can be used with the following optional data capture accessories:

- RS4000 laser scanner
- RS5000 corded imager
- RS5100 Bluetooth Ring Scanner
- RS6000 Hands-free imager
- RS507/RS507X Hands-free imager.

Laser Scanning

The device with an optional RS4000 laser scanner has the following features:

- Reading of a variety of bar code symbologies, including the most popular linear and 1D code types.
- Advanced intuitive laser aiming for easy point-and-shoot operation
- Adaptive scanning.

Scanning Bar Codes



NOTE: Scanning procedures depend on the application and device configuration. An application may use different scanning procedures from the one listed below.

Imaging

The device with an optional RS507, RS5000 or RS6000 imager has the following features:

- Omnidirectional (360°) reading of a variety of bar code symbologies, including the most popular linear, postal, PDF417, and 2D matrix code types.
- Advanced intuitive laser aiming for easy point-and-shoot operation.

The imager uses imaging technology to take a picture of a bar code, stores the resulting image in its memory, and executes state-of-the-art software decoding algorithms to extract the bar code data from the image.

Operational Modes

The optional imager supports two modes of operation. Activate each mode pressing the **Scan** button.

- **Decode Mode:** In this mode, the imager attempts to locate and decode bar codes within its field of view. The imager remains in this mode as long as the user holds the scan button, or until it decodes a bar code.



NOTE: To enable Pick List Mode use **DataWedge**. Pick List can also be set in an application using a API command.

- **Pick List Mode:** This mode allows the user to selectively decode a bar code when more than one bar code is in the imager's field of view. To accomplish this, move the aiming crosshair center dot over the required bar code to decode only that bar code. This feature is ideal for pick lists containing multiple bar codes and manufacturing or transport labels containing more than one bar code (either 1D or 2D).

RS4000 Ring Scanner

The RS4000 ring scanner is a modular, wearable laser scanner that allows the operator hands-free bar code scanning capability.

Figure 18 RS4000 Ring Scanner

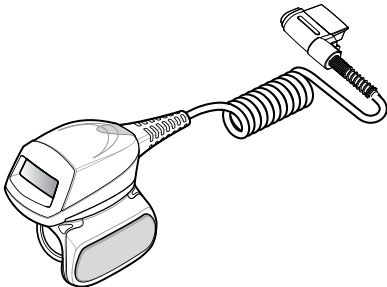

Refer to the RS4000 Ring Scanner Quick Start Guide for more information.

RS5000 Ring Scanner

The RS5000 ring scanner is a modular, wearable imager scanner that allows the operator hands-free bar code scanning capability.

Figure 19 RS5000 Ring Scanner

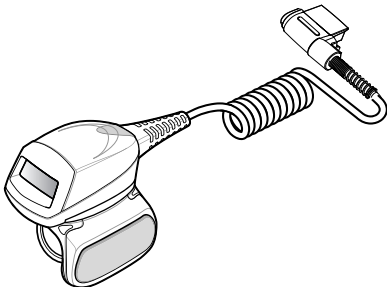

RS5100 Ring Scanner

The RS5100 Ring Scanner is a wearable barcode scan solution for both 1D and 2D bar code symbologies.

Figure 20 RS5100 Ring Scanner

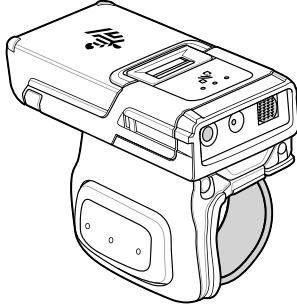

Refer to the RS5100 Ring Scanner Product Reference Guide for more information.

RS6000 Bluetooth Ring Scanner

The RS6000 Bluetooth Ring Scanner is a wearable bar code scan solution for both 1D and 2D bar code symbologies.

Figure 21 RS6000 Bluetooth Ring Scanner

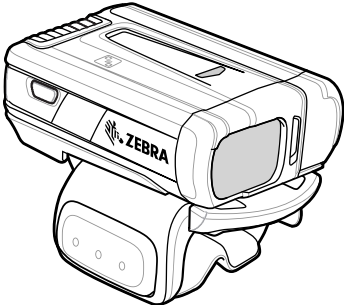

Refer to the RS6000 Bluetooth Ring Scanner Product Reference Guide for more information.

RS507/X Hands-Free Imager

The RS507/X Hands-free Imager is a wearable barcode scan solution for both 1D and 2D barcode symbologies.

Figure 22 RS507/X Hands-Free Imager

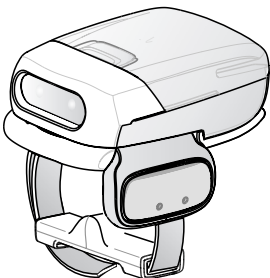

Refer to the RS507/X Hands-free Imager Product Reference Guide for more information.

Scanning Considerations

Typically, scanning is a simple matter of aim, scan/decode and a few quick trial efforts master it. However, two important considerations can be used to optimize any scanning performance:

- Range

Any scanning device decodes well over a particular working range - minimum and maximum distances from the bar code. This range varies according to bar code density and scanning device optics.

Scanning within range brings quick and constant decodes; scanning too close or too far away prevents decodes. Move the scanner closer and further away to find the right working range for the bar codes being scanned. However, the situation is complicated by the availability of various integrated scanning modules. The best way to specify the appropriate working range per bar code density is through a chart called a decode zone for each scan module. A decode zone simply plots working range as a function of minimum element widths of bar code symbols.

- Angle

Scanning angle is important for promoting quick decodes. When laser beams reflect directly back into the scanner from the bar code, this specular reflection can “blind” the scanner.

To avoid this, scan the bar code so that the beam does not bounce directly back. But don't scan at too sharp an angle; the scanner needs to collect scattered reflections from the scan to make a successful decode. Practice quickly shows what tolerances to work within.



NOTE: Contact the Zebra Global Support Center if chronic scanning difficulties develop. Decoding of properly printed bar codes should be quick and effortless.

Bar Code Capture with RS4000

To read a bar code, a scan-enabled application is required. The device contains the **DataWedge** application that allows the user to enable the scanner to decode bar code data and display the bar code content.

1. Connect the RS4000 to the device. See [RS4000 Scanner on page 125](#) for more information.
2. Ensure that a scan enabled application is loaded or DataWedge is enabled.
3. Press the trigger.
4. Aim the scan beam at the bar code.

Ensure the red scan beam covers the entire bar code. The Decode LED lights red to indicate that scanning is in process, then lights green and a beep sounds, by default, to indicate the bar code was decoded successfully.



5. Release the trigger.

Adaptive Scanning

The RS4000 contains the adaptive scanning feature that automatically adjusts the scan beam width for rapid and easy scanning of bar codes from near contact to more than 200 inches away.

By default the RS4000 is set to wide scan beam width. When the user presses the trigger, the RS4000 determines the distance from the bar code. For close bar codes the RS4000 sets a wide beam width and for far bar codes it sets a narrow beam width. The RS4000 uses distance, bar code type and material to determine the correct scan beam width.

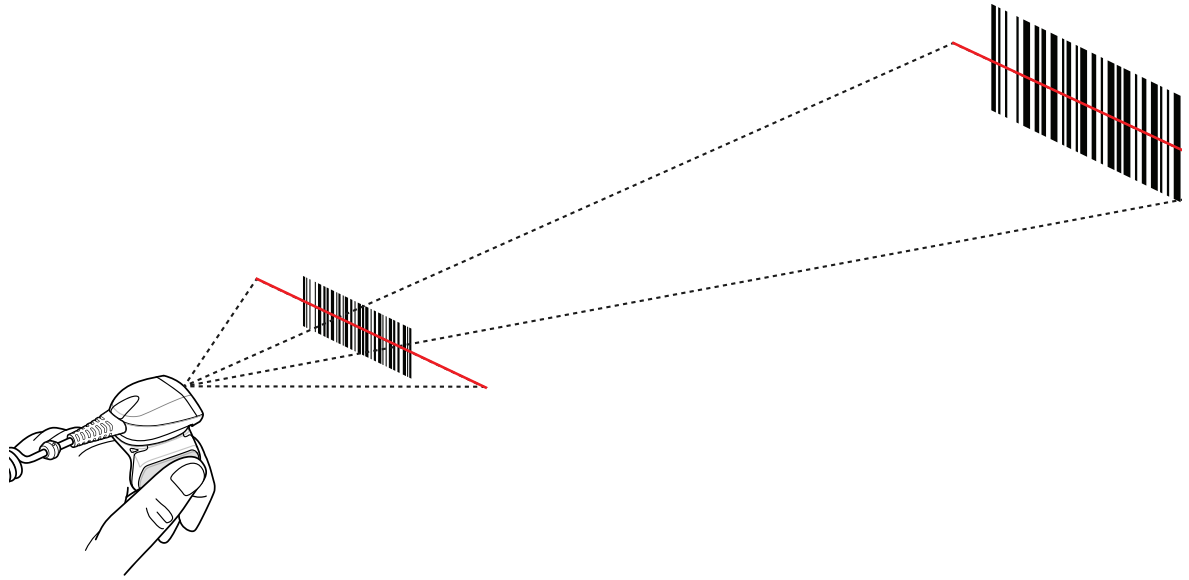

Bar Code Capture with RS5000 Corded Imager

To read a bar code, a scan-enabled application is required. The device contains the **DataWedge** application that allows the user to enable the scanner to decode bar code data and display the bar code content. See [DataWedge on page 65](#) for more information on launching DataWedge.

1. Connect the RS5000 to the device. See [RS5000 Imager on page 127](#) for more information.
2. Press the scan trigger and aim the RS5000 at a bar code.
3. Ensure the bar code is within the area formed by the aiming pattern. The aiming dot is used for increased visibility in bright lighting conditions.

Figure 23 RS5000 Aiming Pattern

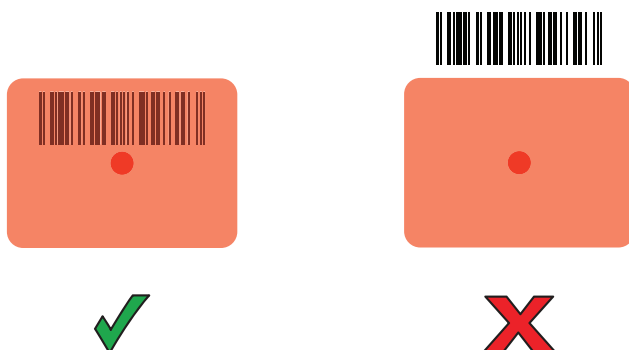

Figure 24 RS5000 Pick List Mode with Multiple Bar Codes

4. If the decode is successful the LED lights green. The terminal beeps if programmed accordingly.



NOTE: Imager decoding usually occurs instantaneously. The RS5000 repeats the steps required to take a digital picture (image) of a poor or difficult bar code as long as the scan button remains pressed.

Scanning with RS5100 Ring Scanner

To read a barcode, a scan-enabled app is required. The device contains the DataWedge app that allows you to enable the scanner to decode barcode data and display the barcode content.

To scan with the RS5100:

1. Pair the RS5100 with the device.
2. Ensure that an app is open on the device and a text field is in focus (text cursor in text field).
3. Point the RS5100 at a barcode.

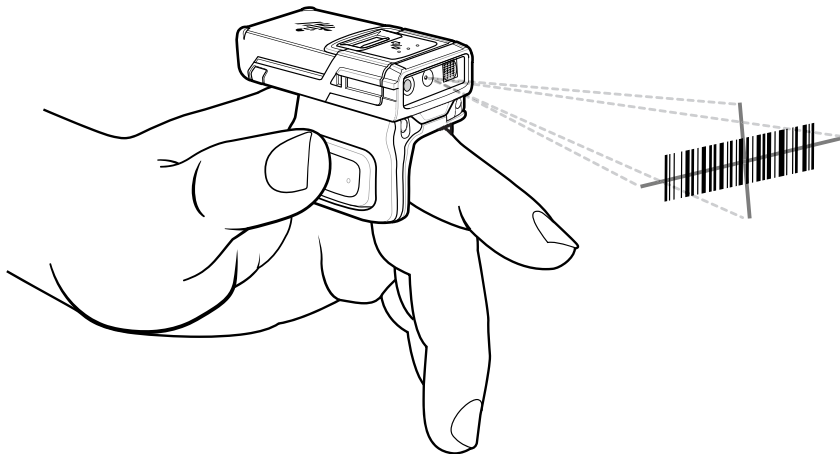
Figure 25 Barcode Scanning with RS5100

4. Press and hold the trigger.

The red laser aiming pattern turns on to assist in aiming. Ensure the barcode is within the area formed by the cross-hairs in the aiming pattern. The aiming dot increases visibility in bright lighting conditions.

The RS5100 LEDs light green and a beep sounds to indicate the barcode was decoded successfully. When the RS5100 is in Pick List mode, the RS5100 does not decode the barcode until the center of the crosshair touches the barcode.

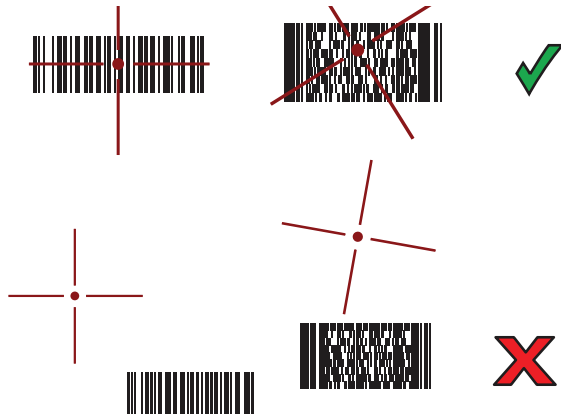
Figure 26 RS5100 Aiming Pattern**Figure 27** RS5100 Pick List Mode with Multiple Barcodes in Aiming Pattern

5. The captured data appears in the text field.

Bar Code Capture with RS6000 Hands-Free Imager

To read a bar code, a scan-enabled application is required. The device contains the **DataWedge** application that allows the user to enable the scanner to decode bar code data and display the bar code content. See [DataWedge on page 65](#) for more information on launching DataWedge.

Pair the RS6000 with the device. See [Pairing Using Simple Serial Interface on page 63](#) or [Pairing Using Bluetooth Human Interface Device on page 64](#) for more information.

1. Ensure that an application is open on the device and a text field is in focus (text cursor in text field).
2. Point the RS6000 at a bar code.

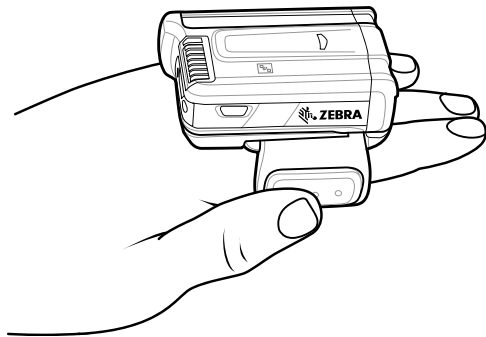

3. Press and hold the trigger.

The red laser aiming pattern turns on to assist in aiming. Ensure the bar code is within the area formed by the cross-hairs in the aiming pattern. The aiming dot is used for increased visibility in bright lighting conditions.

The RS6000 LEDs light green, a beep sounds to indicate the bar code was decoded successfully. Note that when the RS6000 is in Pick List Mode, the RS6000 does not decode the bar code until the center of the crosshair touches the bar code.

Figure 28 Aiming Pattern

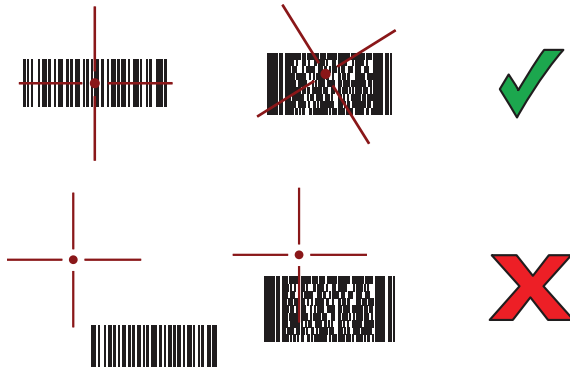

Figure 29 Pick List Mode with Multiple Bar Codes in Aiming Pattern



4. The captured data appears in the text field.

Bar Code Capture with RS507/X Hands-Free Imager

To read a bar code, a scan-enabled application is required. The device contains the **DataWedge** application that allows the user to enable the scanner to decode bar code data and display the bar code content. See [DataWedge on page 65](#) for more information on launching DataWedge.

Pair the RS507/X with the device. See [Pairing Using Simple Serial Interface on page 63](#) or [Pairing Using Bluetooth Human Interface Device on page 64](#) for more information.

1. Ensure that an application is open on the device and a text field is in focus (text cursor in text field).

2. Point the RS507/X at a bar code.

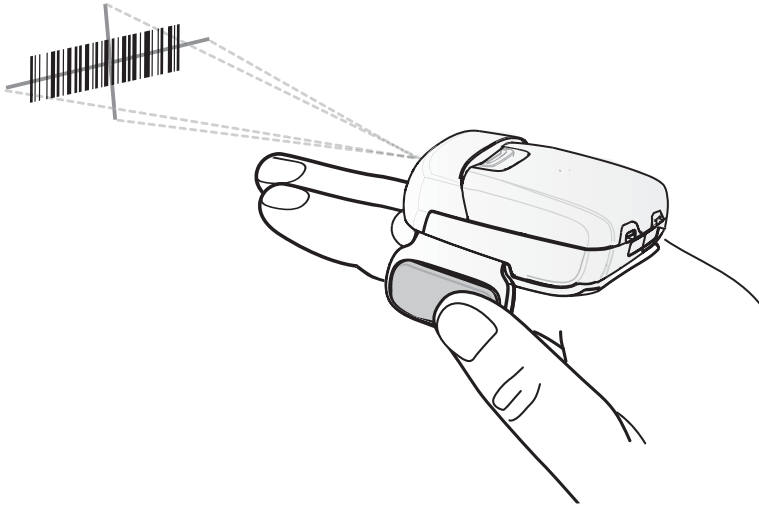

3. Press and hold the trigger.

The red laser aiming pattern turns on to assist in aiming. Ensure the bar code is within the area formed by the cross-hairs in the aiming pattern. The aiming dot is used for increased visibility in bright lighting conditions.

The RS507/X LEDs light green, a beep sounds to indicate the bar code was decoded successfully. Note that when the RS507/X is in Pick List Mode, the RS507/X does not decode the bar code until the center of the crosshair touches the bar code.

Figure 30 Aiming Pattern

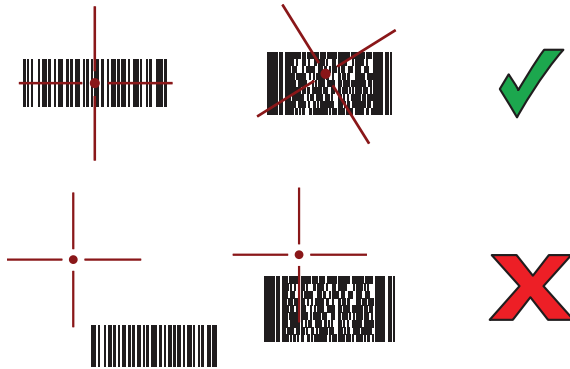

Figure 31 Pick List Mode with Multiple Bar Codes in Aiming Pattern



4. The captured data appears in the text field.

Pairing the RS507/X or RS6000 Hands-Free Imager

To connect the RS507/X or RS6000 imagers to the device, use one of the following methods:

- Near Field Communication (NFC) (RS6000 only)
- Simple Serial Interface (SSI)
- Bluetooth Human Interface Device (HID) Mode.

Pairing Using Near Field Communication

The device provides the ability to pair the RS6000 using NFC.



NOTE: RS6000 only.

1. Ensure that the RS6000 is in SSI mode. Refer to the RS6000 User Guide for more information.
2. Ensure that NFC is enabled on the device.
3. Align the NFC icon on the RS6000 with the NFC icon on the device.

The Status LED blinks blue indicating that the RS6000 is attempting to establish connection with the device. When connection is established, the Status LED turns off and the RS6000 emits a single string of low/high beeps.

A notification appears on the device screen and the  icon appears in the Status bar.

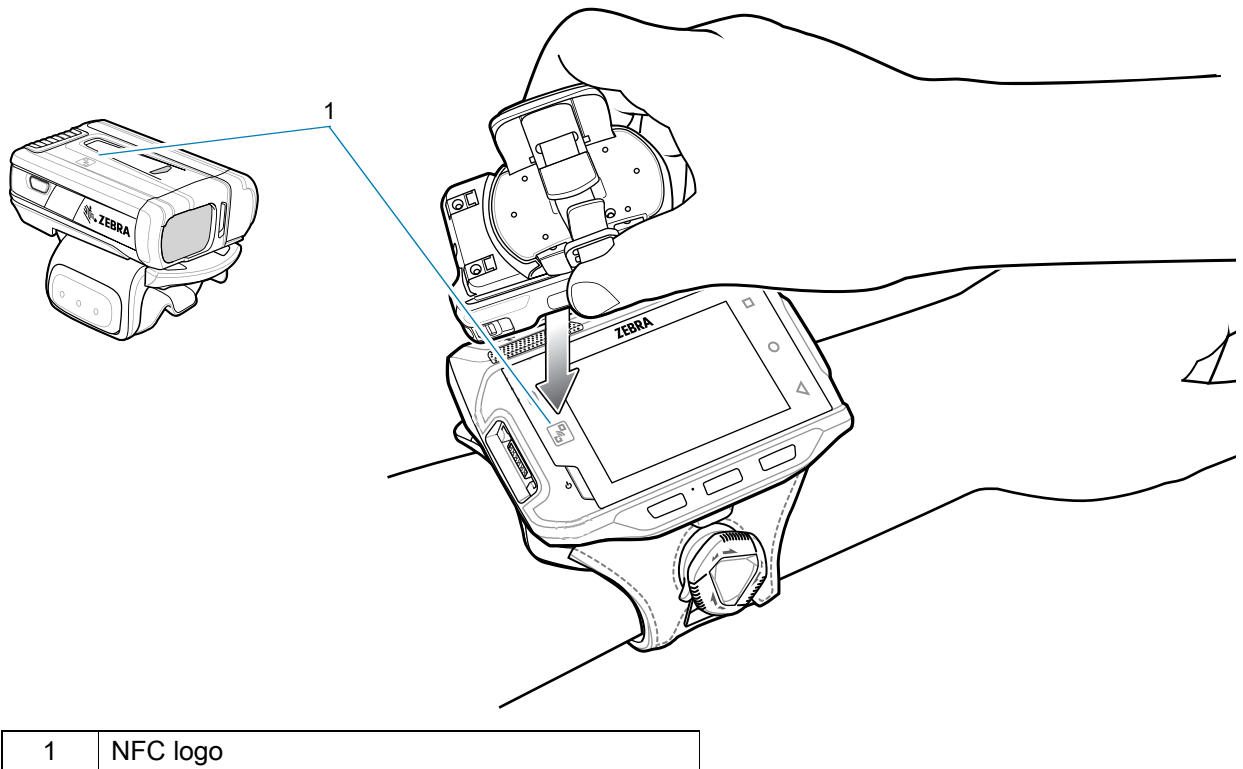

NOTE: Not all Zebra devices support NFC readers and the Tap-to-Pair feature.

Pairing in HID Mode Using Near Field Communication

The device provides the ability to pair the RS6000 in HID Mode using NFC.



NOTE: RS6000 only.

1. Ensure that NFC is enabled on the device.
2. Ensure that Bluetooth is enabled on both devices.
3. Ensure that the Bluetooth device to discover is in discoverable mode.
4. Ensure that the two devices are within 10 meters (32.8 feet) of one another.
5. Place the RS6000 in Human Interface Device (HID) mode. If the RS6000 is already in HID mode, skip to step 6.
 - a. Remove the battery from the RS6000.
 - b. Press and hold the Restore key.
 - c. Install the battery onto the RS6000.
 - d. Keep holding the Restore key for about five seconds until a chirp is heard and the Scan LEDs flash green.
 - e. Scan the bar code below to place the RS6000 in HID mode.

Figure 32 Bluetooth HID Bar Code



6. Remove the battery from the RS6000.
7. Re-install the battery into the RS6000.



CAUTION: Use only the standard 3,350 mAh battery in the RS6000.

- Align the NFC icon on the RS6000 with the NFC icon on the device.

The Status LED blinks blue indicating that the RS6000 is attempting to establish connection with the device. When connection is established, the Status LED turns off and the RS6000 emits a single string of low/high beeps.

A notification appears on the Notification panel and the  icon appears in the Status bar.

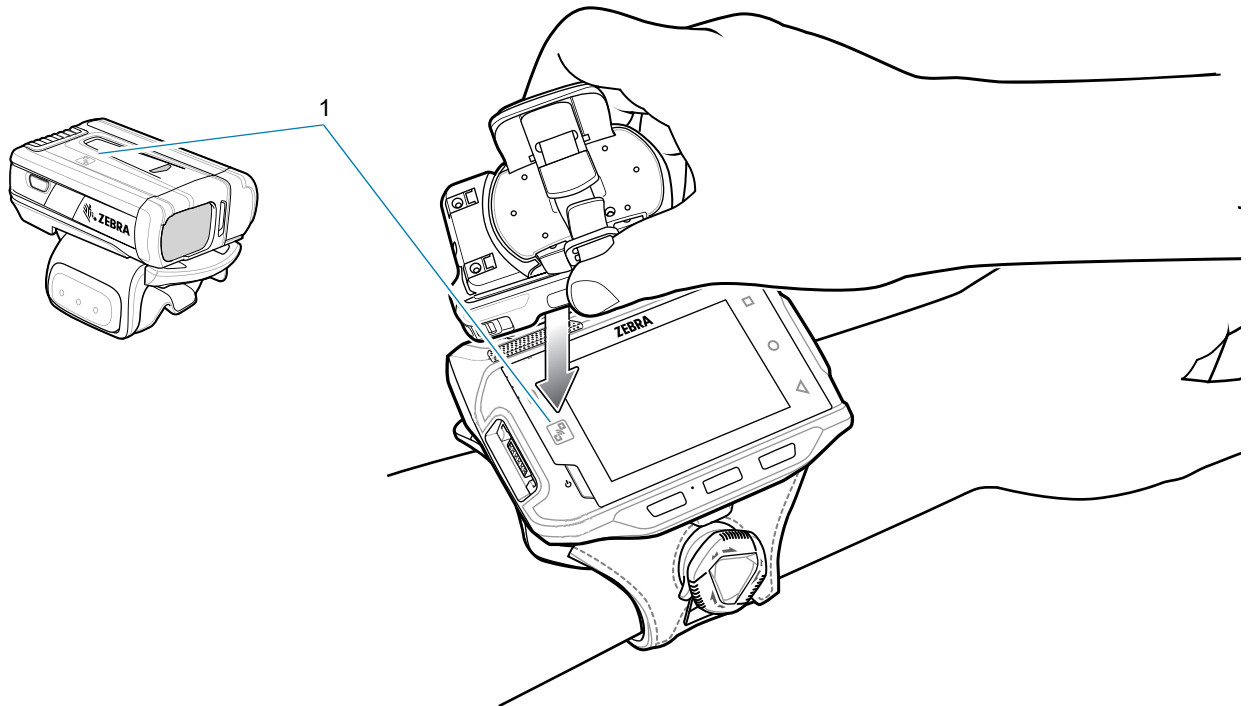

1	NFC logo
---	----------

The device pairs with the RS6000 and  appears in the Status bar.

Pairing Using Simple Serial Interface

To pair the RS507/X or RS6000 with the device using SSI:

- Ensure that the two devices are within 10 meters (32.8 feet) of one another.
- Install the battery into the RS6000.

3. Swipe up from the bottom of the Home screen and touch .



4. Using the RS507/X or RS6000, scan the bar code on the screen.

The RS507/X or RS6000 emits a high/low/high/low beeps. The Scan LED flashes green indicating that the RS507/X or RS6000 is attempting to establish connection with the device. When connection is established, the Scan LED turns off and the RS6000 emits one string of low/high beeps.

A notification appears on the device screen and the  icon appears in the Status bar.

5. On the device touch the Home button.

Pairing Using Bluetooth Human Interface Device

To pair the RS507X/RS6000 with the device using HID:

1. Ensure that Bluetooth is enabled on both devices.
2. Ensure that the Bluetooth device to discover is in discoverable mode.
3. Ensure that the two devices are within 10 meters (32.8 feet) of one another.
4. Place the RS507X/RS6000 in Human Interface Device (HID) mode. If the RS507X/RS6000 is already in HID mode, skip to step 5.
 - a. Remove the battery from the RS507X/RS6000.
 - b. Press and hold the Restore key.
 - c. Install the battery onto the RS507X/RS6000.
 - d. Keep holding the Restore key for about five seconds until a chirp is heard and the Scan LEDs flash green.
 - e. Scan the bar code below to place the RS507X/RS6000 in HID mode.

Figure 33 Bluetooth HID Bar Code



5. Remove the battery from the RS507X/RS6000.
6. Re-install the battery into the RS507X/RS6000.

7. Swipe down from the status bar to open the quick access panel and then touch .
8. Touch **Bluetooth**.
9. Touch **Pair new device**. The device begins searching for discoverable Bluetooth devices in the area and displays them under **Available devices**.
10. Scroll through the list and select RS507X/RS6000.

The device connects to the RS507X/RS6000 and **Connected** appears below the device name. The Bluetooth device is added to the **Bluetooth devices** list and a trusted (“paired”) connection is established.

A notification appears on the Notification panel and the  icon appears in the Status bar.

DataWedge



DataWedge is a utility that adds advanced barcode scanning capability to any application without writing code. It runs in the background and handles the interface to built-in barcode scanners. The captured barcode data is converted to keystrokes and sent to the target application as if it was typed on the keypad. DataWedge allows any app on the device to get data from input sources such as a barcode scanner, MSR, RFID, voice, or serial port and manipulate the data based on options or rules.

Configure DataWedge to:

- Provide data capture services from any app.
- Use a particular scanner, reader or other peripheral device.
- Properly format and transmit data to a specific app.

To configure DataWedge refer to techdocs.zebra.com/datawedge/.

Enabling DataWedge

1. Swipe up from the bottom of the Home screen and touch .
2. Touch  > **Settings**.
3. Touch the **DataWedge enabled** checkbox. A blue checkmark appears in the checkbox indicating that DataWedge is enabled.
4. Touch the Home button.

Disabling DataWedge

1. Touch .
2. Touch **Settings**.
3. Touch **DataWedge enabled**.

The blue check disappears from the checkbox indicating that DataWedge is disabled.

Supported Decoders



NOTE: DataWedge supports the decoders listed below but not all are validated on this device.

Table 12 Supported Decoders

Decoders	RS5100	RS507/RS507X	RS4000	RS5000	RS6000
Australian Postal	O	O	--	O	O
Aztec	X	X	--	X	X
Canadian Postal	O	--	--	--	O
Chinese 2 of 5	O	O	O	O	O
Codabar	X	X	X	X	X
Code 11	O	O	O	O	O
Code 128	X	X	X	X	X
Code 39	X	X	X	X	X
Code 93	O	O	O	O	O
Composite AB	O	O	--	O	O
Composite C	O	O	--	O	O
Discrete 2 of 5	O	O	O	O	O
Datamatrix	X	X	--	X	X
Dutch Postal	O	O	--	O	O
DotCode	O	--	--	--	O
EAN13	X	X	X	X	X
EAN8	X	X	X	X	X
Grid Matrix	O				O
GS1 DataBar	X	X	X	X	X
GS1 DataBar Expanded	X	X	X	X	X
GS1 DataBar Limited	O	O	O	O	O
GS1 Datamatrix	O	--	--	O	O
GS1 QRCode	O	--	--	O	O
HAN XIN	O	--	--	O	O
Interleaved 2 of 5	O	O	O	O	O

Table 12 Supported Decoders (Continued)

Decoders	RS5100	RS507/RS507X	RS4000	RS5000	RS6000
Japanese Postal	O	O	--	O	O
Korean 3 of 5	O	O	O	O	O
MAIL MARK	X	--	--	X	X
Matrix 2 of 5	O	O	O	O	O
Maxicode	X	X	--	X	X
MicroPDF	O	O	--	O	O
MicroQR	O	O	--	O	O
MSI	O	O	O	O	O
PDF417	X	X	X	X	X
QR Code	X	X	--	X	X
Decoder Signature	O	O	--	O	O
TLC 39	O	O	O	O	O
Trioptic 39	O	O	O	O	O
UK Postal	O	O	--	O	O
UPCA	X	X	X	X	X
UPCE0	X	X	X	X	X
UPCE1	O	O	O	O	O
US4state	O	--	--	O	O
US4state FICS	O	--	--	O	O
US Planet	O	O	--	O	O
US Postnet	O	O	--	O	O

Key

X = Enabled

O = Disabled

-- = Not Supported

Touch the Back button to return to the previous screen.

Wireless

This section provides information on the following wireless features:

- Wireless Local Area Network (WLAN)
- Bluetooth

Wireless Local Area Networks

Wireless local area networks (WLANs) allow the device to communicate wirelessly inside a building. Before using the device on a WLAN, the facility must be set up with the required hardware to run the WLAN (sometimes known as infrastructure). The infrastructure and the device must both be properly configured to enable this communication.

Refer to the documentation provided with the infrastructure (access points (APs), access ports, switches, Radius servers, etc.) for instructions on how to set up the infrastructure.

Once the infrastructure is set up to enforce the chosen WLAN security scheme, use the **Wireless & networks** settings configure the device to match the security scheme.

The device supports the following WLAN security options:

- Open
- Wireless Equivalent Privacy (WEP)
- Wi-Fi Protected Access (WPA)/WPA2 Personal (PSK)
- WPA3-Personal
- WPA/WPA2/WPA3 Enterprise (EAP)
 - Protected Extensible Authentication Protocol (PEAP) - with MSCHAPV2 and GTC authentication.
 - Transport Layer Security (TLS)
 - Tunneled Transport Layer Security (TTLS) - with Password Authentication Protocol (PAP), MSCHAP and MSCHAPv2 authentication
 - Flexible Authentication via Secure Tunneling (EAP-FAST) - with MSCHAPV2 and GTC authentication
 - Lightweight Extensible Authentication Protocol (LEAP).
- WPA3-Enterprise 192-bit

The **Status** bar displays icons that indicate Wi-Fi network availability and Wi-Fi status.



NOTE: To extend the life of the battery, turn off Wi-Fi when not in use.

Connecting to a Wi-Fi Network

To connect to a Wi-Fi network:

1. Go to **Settings**.
2. Touch **Wi-Fi** to open the **Wi-Fi** screen. The device searches for WLANs in the area and lists them.
3. Scroll through the list and select the desired WLAN network.
4. For open networks, touch profile once or press and hold and then select **Connect** or for secure networks enter the required password or other credentials then touch **Connect**. See the system administrator for more information.

The device obtains a network address and other required information from the network using the dynamic host configuration protocol (DHCP) protocol. To configure the device with a fixed internet protocol (IP) address, see [Configuring the Device to Use a Static IP Address on page 72](#).

5. In the Wi-Fi setting field, **Connected** appears indicating that the device is connected to the WLAN.

Removing a Wi-Fi Network

To remove a remembered or connected network:

1. Go to **Settings**.
2. Touch **Network & Internet > W-Fi**.
3. Scroll down to the bottom of the list and touch **Saved networks**.
4. Touch the name of the network.
5. Touch **FORGET**.
6. Touch the Home button.

WLAN Configuration

This section provides information on configuring Wi-Fi settings.

Configuring a Secure Wi-Fi Network

1. Go to **Settings**.
2. Touch **Network & Internet > Wi-Fi**.
3. Slide the switch to the **ON** position.
4. The device searches for WLANs in the area and lists them on the screen.
5. Scroll through the list and select the desired WLAN network.
6. Touch the desired network. If the network security is **Open**, the device automatically connects to the network. For all other network security a dialog box appears.
7. If the network security is WPA/WPA2-Personal, WPA3-Personal, or WEP, enter the required password and then touch **Connect**.
8. If the network security is WPA/WPA2/WPA3 Enterprise:
 - Touch the **EAP method** drop-down list and select one of the following:
 - Touch the **Phase 2 authentication** drop-down list and select an authentication method.

- If required, touch **CA certificate** and select a Certification Authority (CA) certificate. Note: Certificates are installed using the **Security** settings.
 - If required, touch **User certificate** and select a user certificate. Note: User certificates are installed using the Security settings.
 - If required, in the **Identity** text box, enter the username credentials.
 - If desired, in the **Anonymous identity** text box, enter an anonymous identity username.
 - If required, in the **Password** text box, enter the password for then given identity.
9. If the network security is **WPA3-Enterprise 192-bit**:
- Touch **CA certificate** and select a Certification Authority (CA) certificate. Note: Certificates are installed using the **Security** settings.
 - Touch **User certificate** and select a user certificate. Note: User certificates are installed using the **Security** settings.
 - In the **Identity** text box, enter the username credentials.
-  **NOTE:** By default, the network Proxy is set to **None** and the IP settings is set to **DHCP**. See Configuring for a Proxy Server for setting connection to a proxy server and see Configuring the Device to Use a Static IP Address for setting the device to use a static IP address.
10. Touch **Connect**.
11. Touch the Home button.

Manually Adding a Wi-Fi Network

Manually add a Wi-Fi network if the network does not broadcast its name (SSID) or to add a Wi-Fi network when out of range.

1. Go to **Settings**.
2. Touch **Network & Internet > Wi-Fi**.
3. Slide the Wi-Fi switch to the **On** position.
4. Scroll to the bottom of the list and select **Add network**.
5. In the **Network name** text box, enter the name of the Wi-Fi network.
6. In the **Security** drop-down list, set the type of security to:
 - **None**
 - **Enhanced Open**
 - **WEP**
 - **WPA/WPA2-Personal**
 - **WPA3-Personal**
 - **WPA/WPA2/WPA3-Enterprise**
 - **WPA3-Enterprise 192-bit**
7. If the network security is **None** , touch **Save**.
8. If the network security is **WEP**, **WPA3-Personal**, or **WPA/WPA2-Personal**, enter the required password and then touch **Save**.
9. If the network security is **WPA/WPA2/WPA3-Enterprise**:

- Touch the **EAP method** drop-down list and select one of the following:
 - **PEAP**
 - **TLS**
 - Touch the **Phase 2 authentication** drop-down list and select an authentication method.
 - If required, touch **CA certificate** and select a Certification Authority (CA) certificate. Note: Certificates are installed using the **Security** settings.
 - If required, touch **User certificate** and select a user certificate. Note: User certificates are installed using the **Security** settings.
 - If required, in the **Identity** text box, enter the username credentials.
 - If desired, in the **Anonymous identity** text box, enter an anonymous identity username.
 - If required, in the **Password** text box, enter the password for the given identity.
10. If the network security is **WPA3-Enterprise 192-bit**:
- Touch **CA certificate** and select a Certification Authority (CA) certificate. Note: Certificates are installed using the **Security** settings.
 - Touch **User certificate** and select a user certificate. Note: User certificates are installed using the **Security** settings.
 - In the **Identity** text box, enter the username credentials.



NOTE: By default, the network Proxy is set to **None** and the IP settings is set to **DHCP**. See [Configuring for a Proxy Server on page 71](#) for setting connection to a proxy server and see [Configuring the Device to Use a Static IP Address on page 72](#) for setting the device to use a static IP address.

11. Touch **Save**. To connect to the saved network, touch and hold on the saved network and select **Connect to network**.
12. Touch the Home button.

Configuring for a Proxy Server

A proxy server is a server that acts as an intermediary for requests from clients seeking resources from other servers. A client connects to the proxy server and requests some service, such as a file, connection, web page, or other resource, available from a different server. The proxy server evaluates the request according to its filtering rules. For example, it may filter traffic by IP address or protocol. If the request is validated by the filter, the proxy provides the resource by connecting to the relevant server and requesting the service on behalf of the client.

It is important for enterprise customers to be able to set up secure computing environments within their companies, making proxy configuration essential. Proxy configuration acts as a security barrier ensuring that the proxy server monitors all traffic between the Internet and the intranet. This is normally an integral part of security enforcement in corporate firewalls within intranets.

1. Go to **Settings**.
2. Touch **Network & Internet > Wi-Fi**.
3. Slide the Wi-Fi switch to the **On** position.
4. In the network dialog box, select and touch a network.
5. Touch **Advanced options**.
6. Touch **Proxy** and select **Manual**.
7. In the **Proxy hostname** text box, enter the address of the proxy server.

8. In the **Proxy port** text box, enter the port number for the proxy server.
9. In the **Bypass proxy for** text box, enter addresses for web sites that are not required to go through the proxy server. Use a comma “,” between addresses. Do not use spaces or carriage returns between addresses.
10. Touch **Connect**.
11. Touch the Home button.

Configuring the Device to Use a Static IP Address

By default, the device is configured to use Dynamic Host Configuration Protocol (DHCP) to assign an Internet protocol (IP) address when connecting to a wireless network.

1. Go to **Settings**.
2. Touch **Network & Internet > Wi-Fi**.
3. Slide the Wi-Fi switch to the **On** position.
4. In the network dialog box, select and touch a network.
5. Touch **Advanced options**.
6. Touch **IP settings** and select **Static**.
7. In the **IP address** text box, enter an IP address for the device.
8. If required, in the **Gateway** text box, enter a gateway address for the device.
9. If required, in the **Network prefix length** text box, enter the prefix length.
10. If required, in the **DNS 1** text box, enter a Domain Name System (DNS) address.
11. If required, in the **DNS 2** text box, enter a DNS address.
12. Touch **Connect**.
13. Touch the Home button.

Wi-Fi Preferences

Use the **Wi-Fi preferences** to configure advanced Wi-Fi settings. From the Wi-Fi screen scroll down to the bottom of the screen and touch **Wi-Fi preferences**.

- **Turn on Wi-Fi automatically** - When enabled, Wi-Fi automatically turns back on when near high quality saved networks.
- **Open network notification** - When enabled, notifies the user when an open network is available.
- **Advanced** - Touch to expand options.
 - **Additional settings** - See Additional Settings.
 - **Install Certificates** – Touch to install certificates.
 - **Network rating provider** - Disabled (AOSP devices). To help determine what constitutes a good Wi-Fi network, Android supports external Network rating providers that provide information about the quality of open Wi-Fi networks. Select one of the providers listed or **None**. If none are available or selected, the Connect to open networks feature is disabled.
 - **Wi-Fi Direct** - Displays a list of devices available for a direct Wi-Fi connection.
 - **MAC address** - Displays the Media Access Control (MAC) address of the device when connecting to Wi-Fi networks.

- **IP address** - Displays the IP address of the device when connecting to Wi-Fi networks.

Additional Wi-Fi Settings



NOTE: Additional Wi-Fi settings are for the device, not for a specific wireless network.

Use the **Additional Settings** to configure additional Wi-Fi settings. To view the additional Wi-Fi settings, scroll to the bottom of the **Wi-Fi** screen and touch **Wi-Fi Preferences > Advanced > Additional settings**.

- **Regulatory**
 - **Country Selection** - Displays the acquired country code if 802.11d is enabled, else it displays the currently selected country code.
 - **Region code** - Displays the current region code.
- **Band and Channel Selection**
 - **Wi-Fi frequency band** - Set the frequency band to: **Auto** (default), **5 GHz only** or **2.4 GHz only**.
- **Logging**
 - **Advanced Logging** – Touch to enable advanced logging or change the log directory.
- **About**
 - **Version** - Displays the current Fusion information.

Wi-Fi Direct

Wi-Fi Direct devices can connect to each other without having to go through an access point. Wi-Fi Direct devices establish their own ad-hoc network when required, letting you see which devices are available and choose which one you want to connect to.

1. Go to **Settings**.
2. Touch **Wi-Fi > Wi-Fi preferences > Advanced > Wi-Fi Direct**. The device begins searching for another Wi-Fi Direct device.
3. Under **Peer devices**, touch the other device name.
4. On the other device, select **Accept**.

Connected appears on the device. On both devices, in their respective Wi-Fi Direct screens, the other device name appears in the list.

Bluetooth

Bluetooth devices can communicate without wires, using frequency-hopping spread spectrum (FHSS) radio frequency (RF) to transmit and receive data in the 2.4 GHz Industry Scientific and Medical (ISM) band (802.15.1). Bluetooth wireless technology is specifically designed for short-range (10 m (32.8 ft)) communication and low power consumption.

Devices with Bluetooth capabilities can exchange information (for example, files, appointments, and tasks) with other Bluetooth enabled devices such as printers, access points, and other mobile devices.

The device supports Bluetooth Low Energy. Bluetooth Low Energy is targeted at applications in the healthcare, fitness, security, and home entertainment industries. It provides reduced power consumption and cost while maintaining standard Bluetooth range.

Adaptive Frequency Hopping

Adaptive Frequency Hopping (AFH) is a method of avoiding fixed frequency interferers, and can be used with Bluetooth voice. All devices in the piconet (Bluetooth network) must be AFH-capable in order for AFH to work. There is no AFH when connecting and discovering devices. Avoid making Bluetooth connections and discoveries during critical 802.11b communications. AFH for Bluetooth consists of four main sections:

- Channel Classification - A method of detecting an interference on a channel-by-channel basis, or pre-defined channel mask.
- Link Management - Coordinates and distributes the AFH information to the rest of the Bluetooth network.
- Hop Sequence Modification - Avoids interference by selectively reducing the number of hopping channels.
- Channel Maintenance - A method for periodically re-evaluating the channels.

When AFH is enabled, the Bluetooth radio “hops around” (instead of through) the 802.11b high-rate channels. AFH coexistence allows enterprise devices to operate in any infrastructure.

The Bluetooth radio in this device operates as a Class 1 device power class. The maximum output power is 7.5 mW and the expected range is 30 m (98.4 ft). A definition of ranges based on power class is difficult to obtain due to power and device differences, and whether in open space or closed office space.



NOTE: It is not recommended to perform Bluetooth wireless technology inquiry when high rate 802.11b operation is required.

Security

The current Bluetooth specification defines security at the link level. Application-level security is not specified. This allows application developers to define security mechanisms tailored to their specific need. Link-level security occurs between devices, not users, while application-level security can be implemented on a per-user basis. The Bluetooth specification defines security algorithms and procedures required to authenticate devices, and if needed, encrypt the data flowing on the link between the devices. Device authentication is a mandatory feature of Bluetooth while link encryption is optional.

Pairing of Bluetooth devices is accomplished by creating an initialization key used to authenticate the devices and create a link key for them. Entering a common personal identification number (PIN) in the devices being paired generates the initialization key. The PIN is never sent over the air. By default, the Bluetooth stack responds with no key when a key is requested (it is up to user to respond to the key request event). Authentication of Bluetooth devices is based-upon a challenge-response transaction. Bluetooth allows for a PIN or passkey used to create other 128-bit keys used for security and encryption. The encryption key is derived from the link key used to authenticate the pairing devices. Also worthy of note is the limited range and fast frequency hopping of the Bluetooth radios that makes long-distance eavesdropping difficult.

Recommendations are:

- Perform pairing in a secure environment
- Keep PIN codes private and do not store the PIN codes in the device
- Implement application-level security.

Bluetooth Profiles

The device supports the Bluetooth services listed.

Table 13 Bluetooth Profiles

Profile	Description
Service Discovery Protocol (SDP)	Handles the search for known and specific services as well as general services.
Serial Port Profile (SPP)	Allows use of RFCOMM protocol to emulate serial cable connection between two Bluetooth peer devices. For example, connecting the device to a printer.
Object Push Profile (OPP)	Allows the device to push and pull objects to and from a push server.
Advanced Audio Distribution Profile (A2DP)	Allows the device to stream stereo-quality audio to a wireless headset or wireless stereo speakers.
Audio/Video Remote Control Profile (AVRCP)	Allows the device to control A/V equipment to which a user has access. It may be used in concert with A2DP.
Personal Area Network (PAN)	Allows the use of Bluetooth Network Encapsulation Protocol to provide L3 networking capabilities over a Bluetooth link. Only PANU role is supported.
Human Interface Device Profile (HID)	Allows Bluetooth keyboards, pointing devices, gaming devices and remote monitoring devices to connect to the device.
Headset Profile (HSP)	Allows a hands-free device, such as a Bluetooth headset, to place and receive calls on the device.
Hands-Free Profile (HFP)	Allows car hands-free kits to communicate with the device in the car.
Out of Band (OOB)	Allows exchange of information used in the pairing process. Pairing is completed using the Bluetooth radio, but requires information from the OOB mechanism. Using OOB with NFC enables pairing when devices simply get close, rather than requiring a lengthy discovery process.
Symbol Serial Interface (SSI)	Allows for communication with Bluetooth Imager.

Bluetooth Power States

The Bluetooth radio is off by default.

- Suspend - When the device goes into suspend mode, the Bluetooth radio stays on.
- Airplane Mode - When the device is placed in Airplane Mode, the Bluetooth radio turns off. When Airplane mode is disabled, the Bluetooth radio returns to the prior state. When in Airplane Mode, the Bluetooth radio can be turned back on if desired.

Bluetooth Radio Power

Turn off the Bluetooth radio to save power or if entering an area with radio restrictions (for example, an airplane). When the radio is off, other Bluetooth devices cannot see or connect to the device. Turn on the Bluetooth radio to exchange information with other Bluetooth devices (within range). Communicate only with Bluetooth radios in close proximity.



NOTE: To achieve the best battery life, turn off radios when not in use.

Enabling Bluetooth

1. Swipe down from the Status bar to open the Notification panel.
2. Touch  to turn Bluetooth on.
3. Touch the Home button.

Disabling Bluetooth

1. Swipe down from the Status bar to open the Notification panel.
2. Touch  to turn Bluetooth off.
3. Touch the Home button.

Discovering Bluetooth Device(s)

The device can receive information from discovered devices without pairing. However, once paired, the device and a paired device exchange information automatically when the Bluetooth radio is on.

1. Ensure that Bluetooth is enabled on both devices.
2. Ensure that the Bluetooth device to discover is in discoverable mode.
3. Ensure that the two devices are within 10 meters (32.8 feet) of one another.
4. Swipe down from the Status bar to open the Quick Access panel.
5. Touch and hold **Bluetooth**.
6. Touch **Pair new device**. The device begins searching for discoverable Bluetooth devices in the area and displays them under **Available devices**.
7. Scroll through the list and select a device. The Bluetooth pairing request dialog box appears.
8. Touch **Pair** on both devices.
9. The Bluetooth device is added to the **Paired devices** list and a trusted (“paired”) connection is established.

Changing the Bluetooth Name

By default, the device has a generic Bluetooth name that is visible to other devices when connected.

1. Go to **Settings**.
2. Touch **Connected devices > Connection preferences > Bluetooth**.
3. If Bluetooth is not on, move the switch to turn Bluetooth on.
4. Touch **Device name**.
5. Enter a name and touch **RENAME**.
6. Touch the Home button.

Connecting to a Bluetooth Device

Once paired, connect to a Bluetooth device.

1. Go to **Settings**.
2. Touch **Connected devices > Connection preferences > Bluetooth**.

3. In the list, touch the unconnected Bluetooth device.

When connected, **Connected** appears below the device name.

Selecting Profiles on the Bluetooth Device

Some Bluetooth devices have multiple profiles.

1. Go to **Settings**.
2. Touch **Connected devices > Connection preferences > Bluetooth**.
3. In the **Paired Devices** list, touch  next to the device name.
4. Turn on or off a profile to allow the device to use that profile.
5. Touch the Home button.

Unpairing a Bluetooth Device

Unpairing a Bluetooth device erases all pairing information.

1. Go to **Settings**.
2. Touch **Connected devices > Connection preferences > Bluetooth**.
3. In the **Paired Devices** list, touch  next to the device name.
4. Touch **FORGET**.
5. Touch the Home button.

Cast

Use **Cast** to mirror the device screen on a Miracast enabled wireless display.

1. Go to **Settings**.
2. Touch **Connected devices > Connection preferences > Cast**.
3. Touch  > **Enable wireless display**.
The device searches for nearby Miracast devices and lists them.
4. Touch a device to begin casting.
5. Touch the Home button.

Near Field Communications

NFC/HF RFID is a short-range wireless connectivity technology standard that enables secure transaction between a reader and a contactless smartcard. The technology is based on ISO/IEC 14443 type A and B (proximity) ISO/IEC 15693 (vicinity) standards, using the HF 13.56 MHz unlicensed band.

The device supports the following operating modes:

- Reader mode
- Peer-to-Peer communication
- Card Emulation mode.

Using NFC, the device can:

- Read contactless cards such as contactless tickets, ID cards and ePassport.
- Read and write information to contactless cards such as SmartPosters and tickets, as well as devices with NFC interface such as vending machines.
- Read information from supported medical sensors.
- Pair with supported Bluetooth devices such as printers , ring scanners (ex. RS6000), and headsets (ex. HS3100).
- Exchange data with another NFC device.
- Emulate contactless card such as ticket, or SmartPoster.

The device NFC antenna is positioned to read NFC cards from the top of the device while the device is being held.

Reading NFC Cards

Read contactless cards using NFC.

Figure 34 Reading Cards

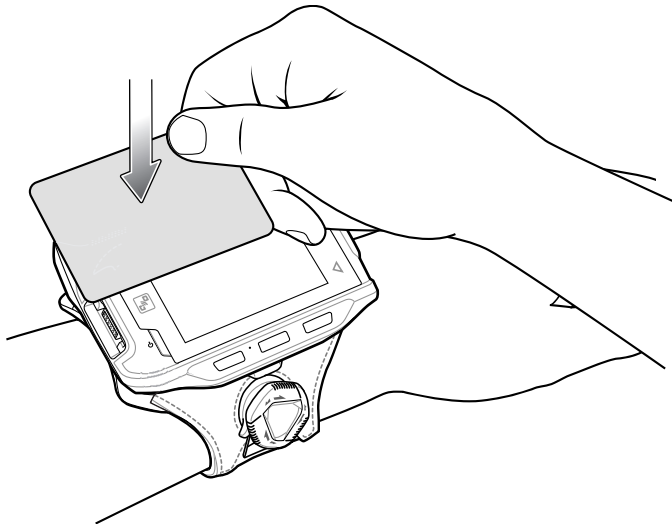

1. Launch an NFC enabled application.
2. Hold device as shown.
3. Move the device close to the NFC card until it detects the card.
4. Hold the card steadily until the transaction is complete (usually indicated by the application).

Enterprise NFC Settings

Improve NFC performance or increase battery life by selecting which NFC features to use on the device.

- **Card Detection Mode** - Select a card detection mode.
 - **Low** - Increases battery life by lowering the NFC detection speed.
 - **Hybrid** - Provides a balance between NFC detection speed and battery life (default).

- **Standard** - Provides the best NFC detection speed, but reduces battery life.
- **Supported Card Technology** - Select an option to detect only one NFC tag type, increasing battery life, but reducing detection speed.
 - **All (Default)** - Detects all NFC tag types. This provides the best detection speed, but reduces battery life.
 - **ISO 14443 Type A/B**
 - **FeliCa**
 - **ISO15693**
- **Other NFC settings available with Zebra administrator tools (CSP)** - Allows configuration of additional Enterprise NFC Settings through staging tools and Mobile Device Management (MDM) solutions with an MX version that supports the Enterprise NFC Settings Configuration Service Provider (CSP). For more information on using the Enterprise NFC Settings CSP, refer to: techdocs.zebra.com.

Accessories

This section provides information for using the accessories for the device. This table lists the accessories available for the device.

Table 14 Accessories

Accessory	Part Number	Description
Cradles		
1-Slot Charging Cradle	CRD-NGWT-1S1BU-01	Provides device and spare battery charging and USB communication with a host computer. Use with power supply, p/n PWRS-14000-148R and country specific grounded AC line cord.
2-Slot Device/RS6000 Charging Cradle	CRD-NWTRS-2SUCH-01	Provides the device and RS6000 charging and USB communication with a host computer. Use with power supply, p/n PWRS-14000-148R and country specific grounded AC line cord.
5-Slot Charge Only Cradle	CRD-NGWT-5S5BC-01	Charges up to five devices and five spare batteries. Use with power supply, p/n PWRS-14000-241R, DC line cord, p/n 50-16002-029R and country specific grounded AC line cord.
10-Slot Device/RS6000 Charge Only Cradle	CRD-NWTRS-10SCH-01	Charges up to five devices and up to five RS6000 scanners. Use with power supply, p/n PWRS-14000-241R, DC line cord, p/n 50-16002-029R and country specific grounded AC line cord.
10-Slot Charge Only Cradle	CRD-NGWT-10SCH-01	Charges up to 10 devices. Use with power supply, p/n PWRS-14000-241R, DC line cord, p/n 50-16002-029R and country specific grounded AC line cord.
5-Slot Ethernet Cradle	CRD-NGWT-5S5BE-01	Charges up to five devices and five spare batteries and provides Ethernet communication. Use with power supply, p/n PWRS-14000-241R, DC line cord, p/n 50-16002-029R and country specific grounded AC line cord.

Table 14 Accessories (Continued)

Accessory	Part Number	Description
Batteries and Chargers		
Replacement Standard Battery	BTRY-NWTRS-33MA-01	Replacement standard 3,350 mAh battery for the device and RS6000 (single pack).
Replacement Extended Battery	BTRY-NGWT-50MA-01	Replacement extended 5,000 mAh battery for WT6300 only (single pack).
4-Slot Battery Charger	SAC-NWTRS-4SCH-01	Charges up to four spare batteries. Requires power supply, p/n PWRS-14000-148R and country specific grounded AC line cord.
20-Slot Battery Charger	SAC-NWTRS-20SCH-01	Charges up to 20 spare batteries. Use with power supply, p/n PWRS-14000-241R, DC line cord, p/n 50-16002-029R and country specific grounded AC line cord.
Mounting Brackets		
Rack Mount Bracket	BRKT-SCRD-SMRK-01	Use for mounting a 5-Slot cradle or four 4-Slot Battery Chargers on a rack.
Cables		
Headset Adapter Cable with Quick Disconnect (Long)	CBL-NGWT-AUQDLG-01	Connects a wired headset to the device on a Hip Mount.
Headset Adapter Cable with Quick Disconnect (Short)	CBL-NGWT-AUQDST-01	Connects a wired headset to the device on a Wrist Mount.
USB/Charge Cable	CBL-NGWT-USBCHG-01	Provides USB communication and power to the device. Requires power supply PWRS-14000-249R and country specific un-grounded AC line cord.
Vibrating Cable	CBL-NGWT-HDV BAP-01	Provides haptic notification feedback.
DC Y Cable	25-122026-02R	Provides power from the PWRS-14000-148R power supply to two 4-Slot Battery Chargers.
DC 4-way Cable	25-85992-01R	Provides power from the PWRS-14000-241R power supply to four 4-Slot Battery Chargers.
DC Line Cord	50-16002-029R	Provides power from the power supply to the 5-Slot Charge Only Cradle, 5-Slot Ethernet Cradle, 5-Slot Charge Only Cradle with Battery Charge and 5-Slot Ethernet Cradle with Battery Charger.
Power Supplies		
Power Supply	PWRS-14000-249R	Provides power to the device using the USB and Charging Cable. Requires country specific un-grounded AC line cord.
Power Supply	PWRS-14000-148R	Provides power to the 2-Slot cradles and 4-Slot Spare Battery Charger. Requires country specific grounded AC line cord.

Table 14 Accessories (Continued)

Accessory	Part Number	Description
Power Supply	PWRS-14000-241R	Provides power to the 5-Slot Charge Only Cradle, 5-Slot Ethernet Cradle, 5-Slot Charge Only Cradle with Battery Charger and the 5-Slot Ethernet Cradle with Battery Charger. Requires DC Line Cord, p/n 50-16002-029R and country specific grounded AC line cord.
Miscellaneous		
Screen Protectors	MISC-WT6X-SCRN-01	Provides additional protection for display (5-pack).
Soft Goods		
Hip Mount	SG-NGWT-HPMNT-01	Provides mounting the device on a belt.
Wrist Mount (Small/Medium)	SG-NGWT-WRMTS-01	Replacement strap.
Wrist Mount (Medium/Large)	SG-NGWT-WRMTL-01	Replacement strap.
Spare Straps (Small/Medium)	SG-NGWT-WSTPST-01	Replacement strap.
Spare Straps (Medium/Large)	SG-NGWT-WSTPLN-01	Replacement strap.
Spare Comfort Pad	SG-NGWT-CMPD-01	Replacement Comfort Pad for the Wrist Mount.

Battery Charging

Main Battery Charging

To charge the main battery:

1. Ensure that the cradle is connected to power.
2. Slide the device into the slot in the cradle. The device Charge LED Indicator, indicates the mobile computer battery charging status.
3. Gently press down on the device to ensure proper contact.
4. When charging is complete, remove the device from the cradle slot.

Spare Battery Charging

To charge the spare battery:

1. Connect the charger to a power source.
2. Insert the battery into a spare battery charging slot and gently press down on the battery to ensure proper contact. The spare battery charging LEDs on the front of the cradle indicates the spare battery charging status.
3. When charging is complete, remove the battery from the charging slot.

Table 15 Spare Battery LED Charging Indicators

LED	Indication
Off	The device, RS6000, or battery is not charging. The device, RS6000, or battery is not inserted correctly in the cradle. Cradle is not powered.
Solid Amber	Battery is charging.
Solid Green	Battery charging is complete.
Fast Blinking Red (2 blinks/second)	Charging error, for example: <ul style="list-style-type: none"> • Temperature is too low or too high. • Charging has gone on too long without completion (typically eight hours).
Solid Red	Unhealthy battery is charging or fully charged.

Charging Temperature

Charge batteries in temperatures from 0 °C to 40 °C (32 °F to 104 °F). The battery charger always performs battery charging in a safe and intelligent manner. At higher temperatures (for example, approximately +37 °C (+98 °F)) the battery charger may for small periods of time alternately enable and disable battery charging to keep the battery at acceptable temperatures. The battery charger indicates when charging is disabled due to abnormal temperatures via its LED.

1-Slot USB Charging Cradle



CAUTION: Ensure that you follow the guidelines for battery safety described in [Battery Safety Guidelines on page 152](#).

The 1-Slot USB Charging Cradle:

- Provides 5.4 VDC (nominal) power for operating the device.
- Provides USB communication with a host computer
- Charges a spare battery.

Figure 35 1-Slot USB Charging Cradle

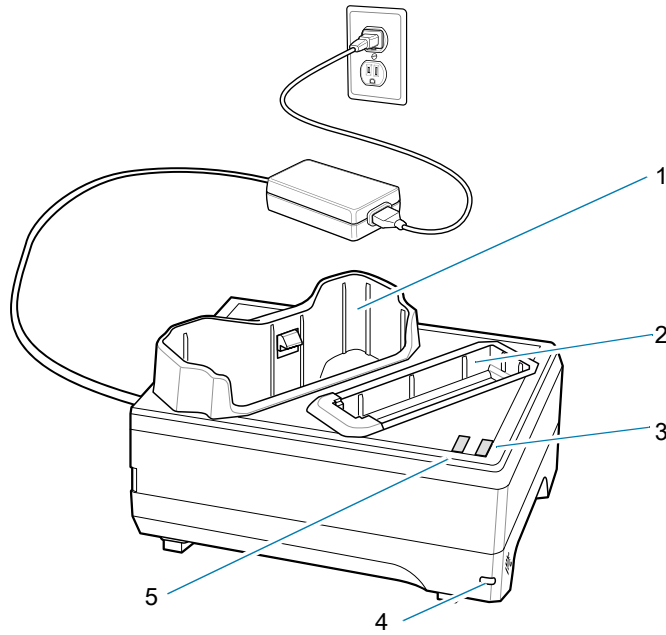

1	Device charging slot
2	Spare battery charging slot
3	Spare battery charging LED
4	Power LED
5	Charging LED

Setup

Figure 36 1-Slot USB Charging Cradle Setup

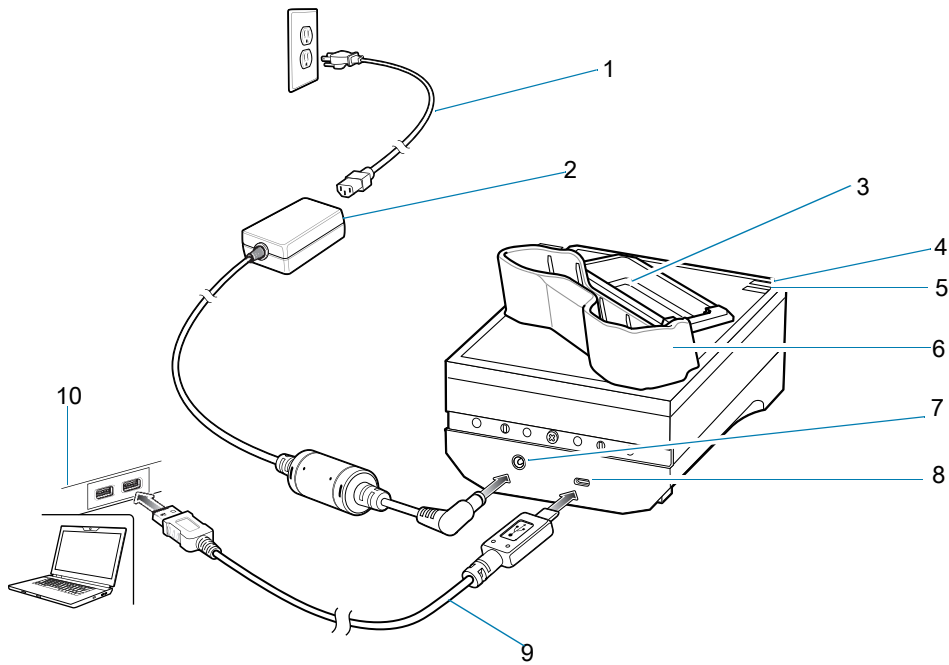

1	AC line cord
2	Power supply
3	Spare battery charging Slot
4	Spare battery charging LED
5	Charging LED
6	Device charging slot
7	Power input
8	USB port
9	USB cable
10	Host computer

Charging the Device

1. If charging a device with a standard battery, insert either end of the device into the device charging slot.

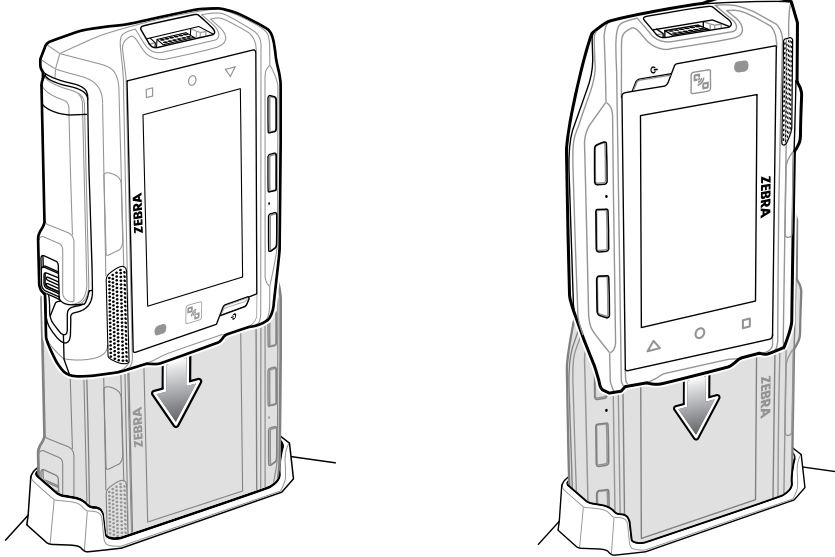

2. If charging a device with a extended battery, insert the end of the device into the device charging slot as shown below.

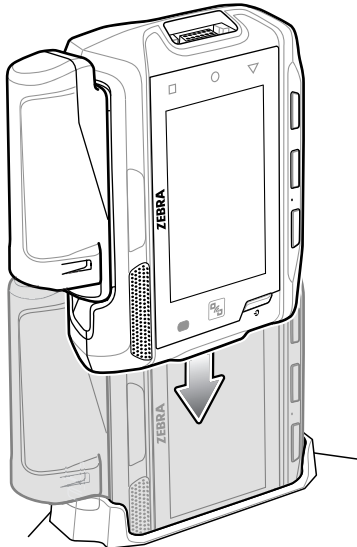

3. Ensure the device is seated properly. The device Charge LED blinks indicating charging.

Charging the Spare Battery

1. Insert a spare battery into the spare battery slot.
2. Gently press down on the battery until it snaps into place.

Figure 37 Insert Battery into Cradle

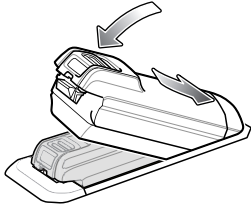
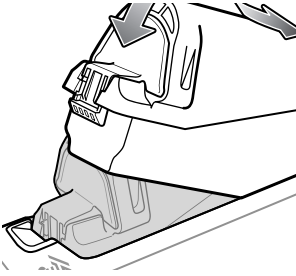

Figure 38 Insert Extended Battery into Cradle



3. Ensure the battery is seated properly. The Spare Battery Charging LED blinks indicating charging.

Battery Removal

To remove the battery, press the battery release latch toward the end of the battery and lift the battery out of the battery slot.

2-Slot Device/RS6000 Charging Cradle



CAUTION: Ensure that you follow the guidelines for battery safety described in [Battery Safety Guidelines](#) on page 152.

The 2-Slot Device/RS6000 Charging Cradle:

- Provides 5.4 VDC (nominal) power for operating the device and RS6000.
- Provides USB communication with a host computer.

Figure 39 2-Slot Device/RS6000 Charging Cradle

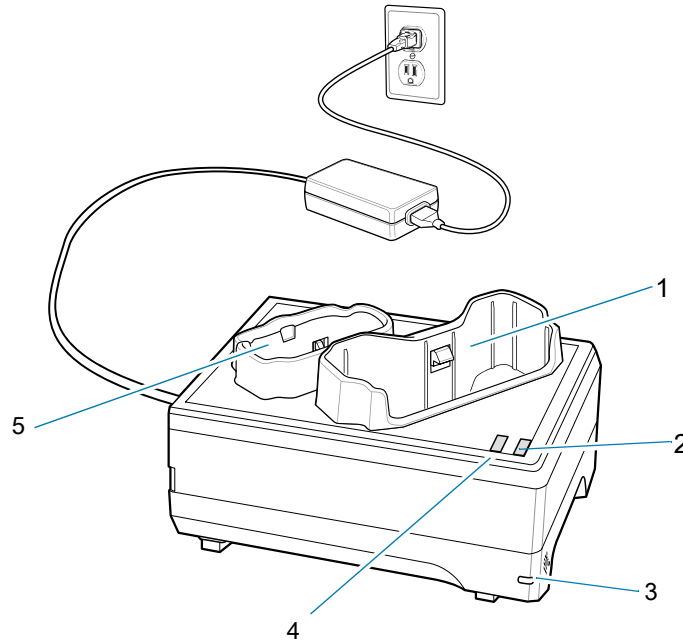

1	Device charging slot
2	Device charging LED
3	Power LED
4	RS6000 charging LED
5	RS6000 charging slot

Setup

Figure 40 2-Slot Device/RS6000 Charging Cradle Setup

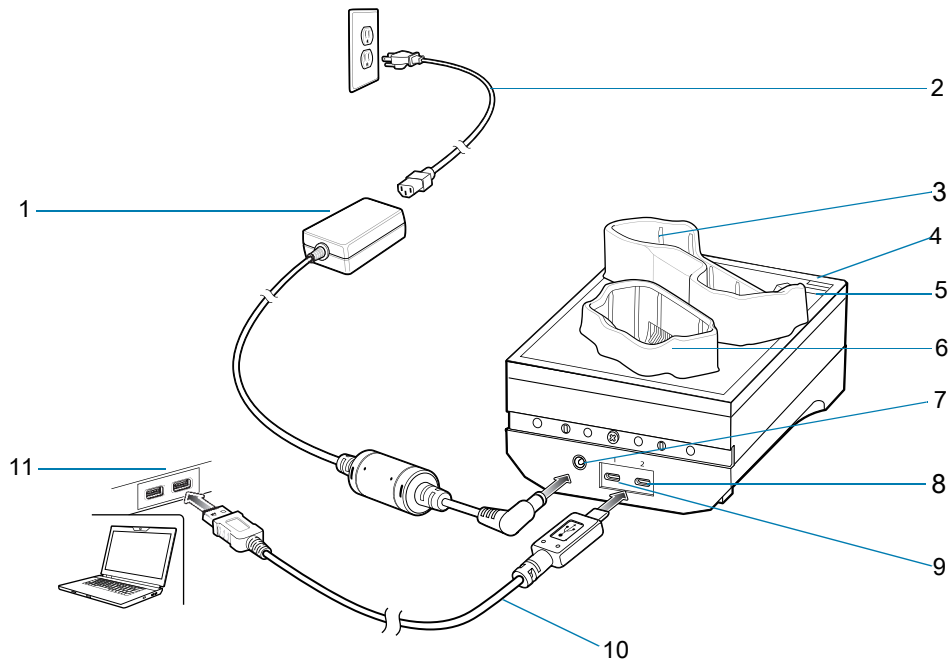

1	Power supply
2	AC line cord
3	Device charging slot
4	Device charging LED
5	RS6000 charging LED
6	RS6000 charging slot
7	Power input
8	Device USB port
9	RS6000 USB port
10	USB cable
11	Host computer

Charging the RS6000

To Charge the RS6000:

1. Insert the RS6000 in the RS6000 charging slot.

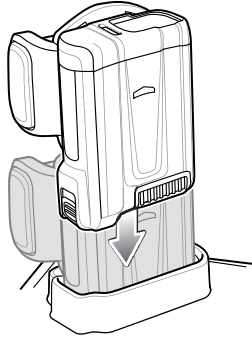

2. Ensure the RS6000 is seated properly. The RS6000 Charging LED blinks indicating charging.

5-Slot Charge Only Cradle



CAUTION: Ensure that you follow the guidelines for battery safety described in [Battery Safety Guidelines](#) on page 152.

The 5-Slot Charge Only Cradle:

- Provides 5.4 VDC (nominal) power for operating up to five devices.
- Simultaneously charges up to five devices.
- Simultaneously charges up to five spare batteries.

Figure 41 5-Slot Charge Only Cradle

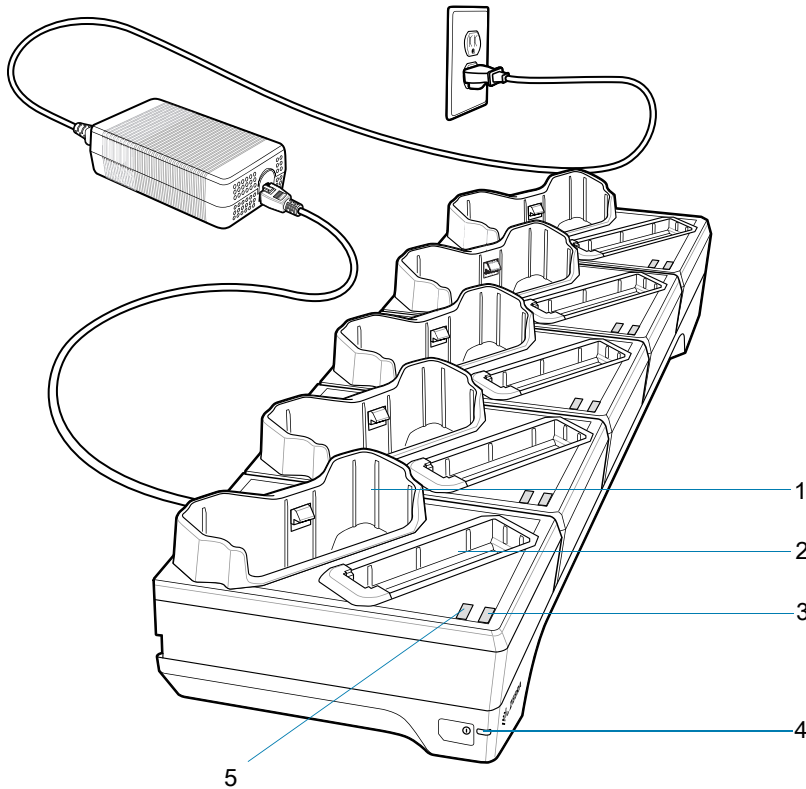

1	Device charging slot
2	Spare battery charging slot
3	Spare battery charging LED
4	Power LED
5	Device charging LED

Setup

Figure 42 5-Slot Charge Only Cradle Setup

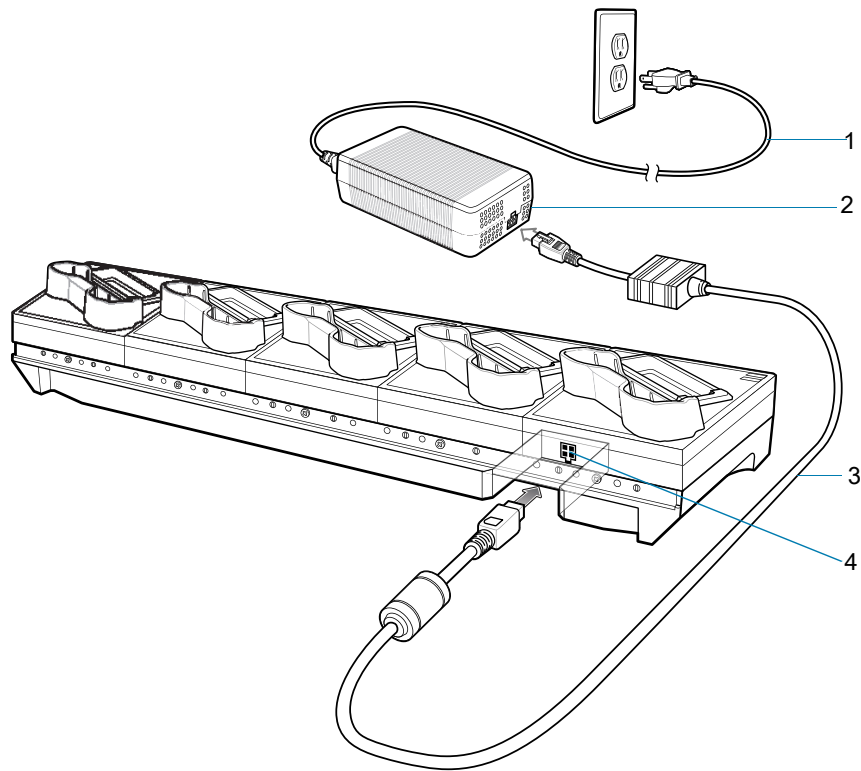

1	AC line cord
2	Power supply
3	DC line cord
4	Power input

Charging the Device

1. If charging a device with a standard battery, insert either end of the device into the device charging slot.

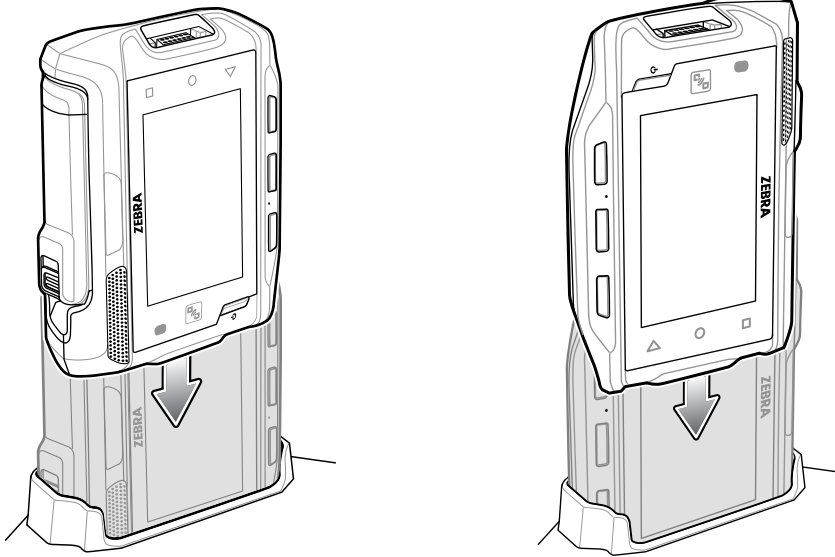

2. If charging a device with a extended battery, insert the end of the device into the device charging slot as shown below.

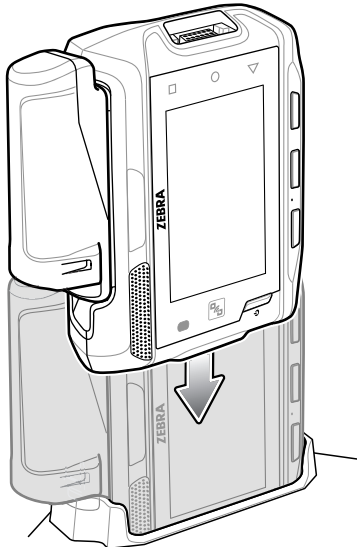

3. Ensure the device is seated properly. The device Charge LED blinks indicating charging.

Charging the Spare Battery

1. Insert a spare battery into the spare battery slot.
2. Gently press down on the battery until it snaps into place.

Figure 43 Insert Battery into Cradle

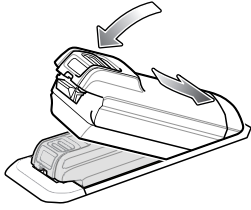
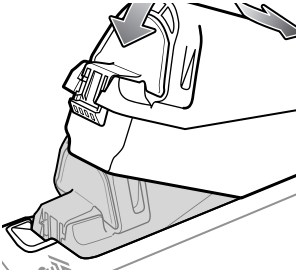

Figure 44 Insert Extended Battery into Cradle



3. Ensure the battery is seated properly. The Spare Battery Charging LED blinks indicating charging.

Battery Removal

To remove the battery, press the battery release latch toward the end of the battery and lift the battery out of the battery slot.

10-Slot Device/RS6000 Charge Only Cradle



CAUTION: Ensure that you follow the guidelines for battery safety described in [Battery Safety Guidelines](#) on page 152.

The 10-Slot Device/RS6000 Charge Only Cradle:

- Provides 5.4 VDC (nominal) power for operating the device and RS6000.
- Simultaneously charges up to five devices.
- Simultaneously charges up to five RS6000's.

Figure 45 10-Slot Device/RS6000 Charge Only Cradle

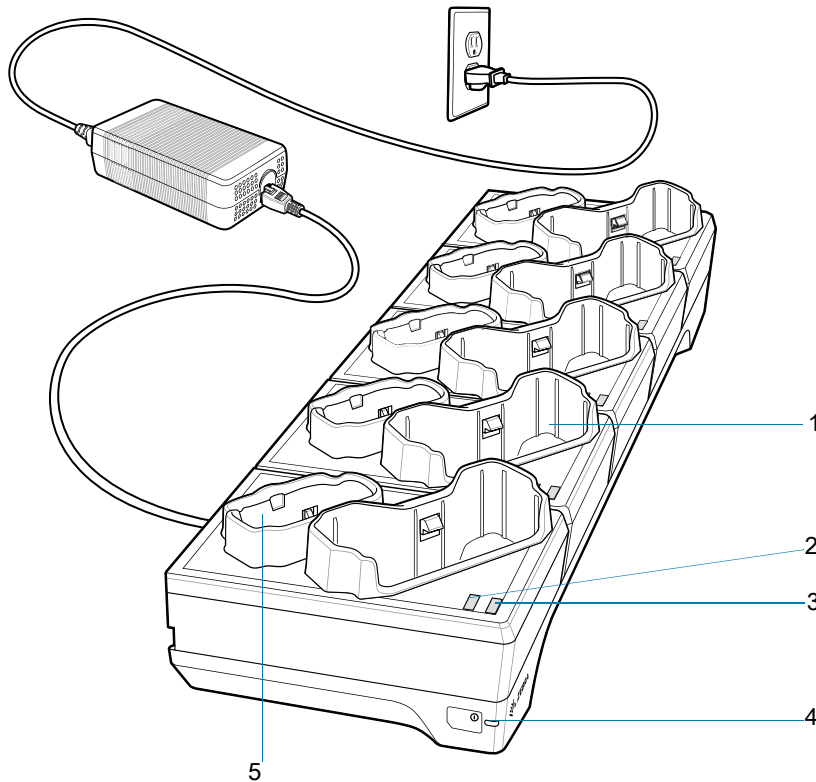

1	Device charging slot
2	RS6000 charging LED
3	Device charging LED
4	Power LED
5	RS6000 charging slot

Setup

Figure 46 10-Slot Device/RS6000 Charge Only Cradle Setup

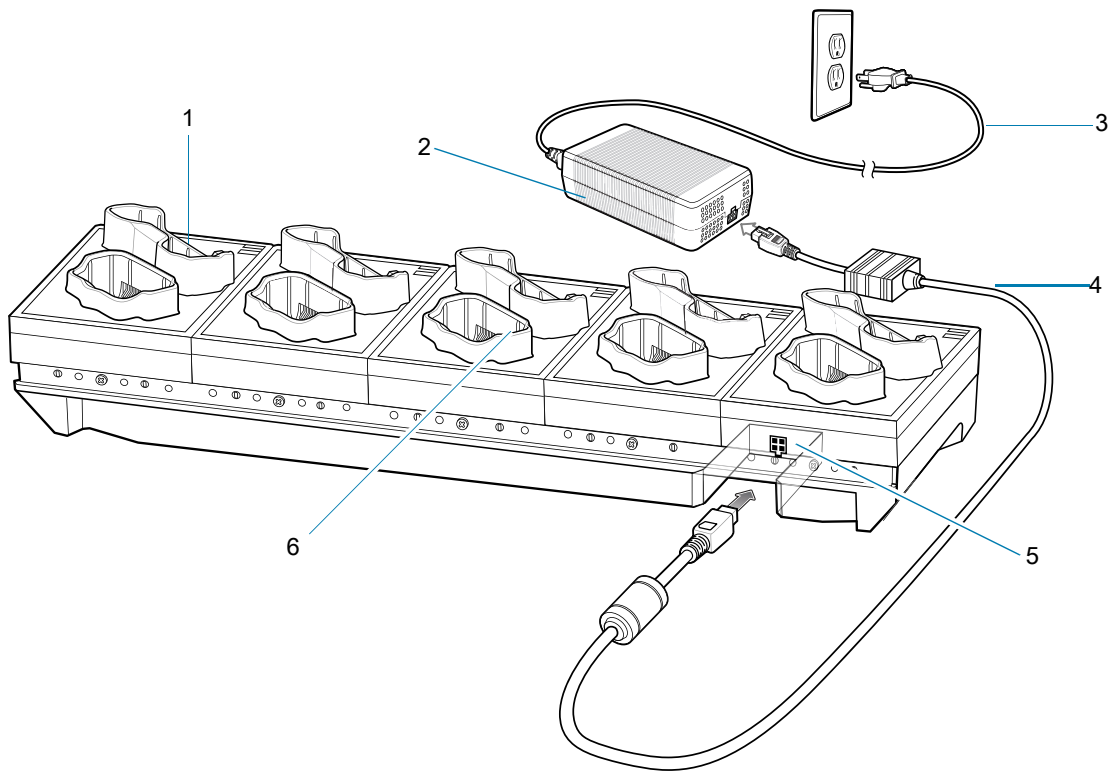

1	Device charging slot
2	Power supply
3	AC line cord
4	DC line cord
5	Power input
6	RS6000 charging slot

Charging the Device

1. If charging a device with a standard battery, insert either end of the device into the device charging slot.

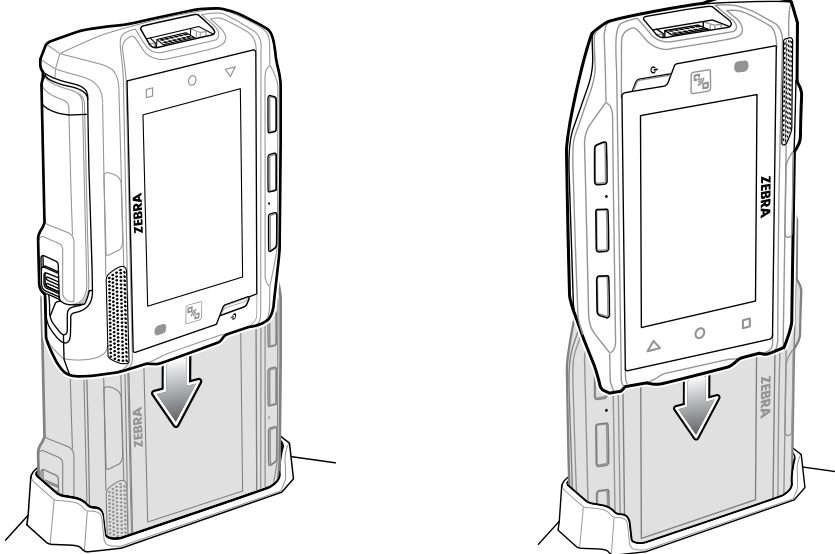

2. If charging a device with a extended battery, insert the end of the device into the device charging slot as shown below.

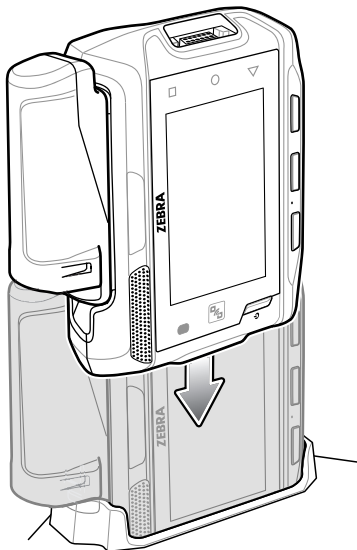

3. Ensure the device is seated properly. The device Charge LED blinks indicating charging.

Charging the RS6000

To Charge the RS6000:

1. Insert the RS6000 in the RS6000 charging slot.

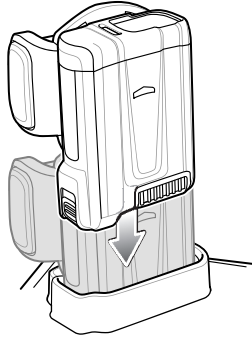

2. Ensure the RS6000 is seated properly. The RS6000 Charging LED blinks indicating charging.

10-Slot Charge Only Cradle



CAUTION: Ensure that you follow the guidelines for battery safety described in [Battery Safety Guidelines](#) on page 152.

The 10-Slot Charge Only Cradle:

- Provides 5.4 VDC (nominal) power for operating the device.
- Simultaneously charges up to 10 devices.

Figure 47 10-Slot Charge Only Cradle

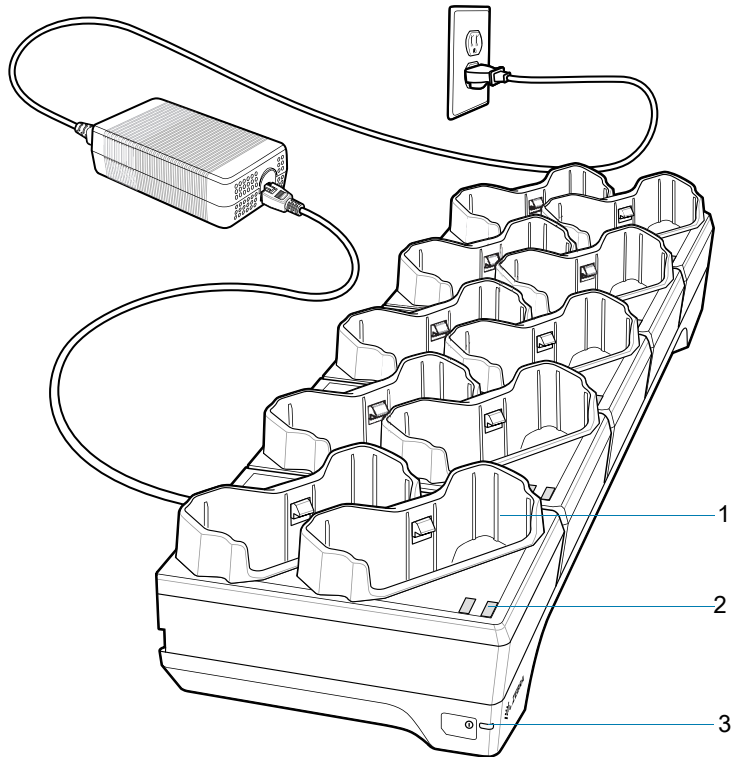

1	Device charging slot
2	Device charging LED
3	Power LED

Setup

Figure 48 10-Slot Charge Only Cradle Setup

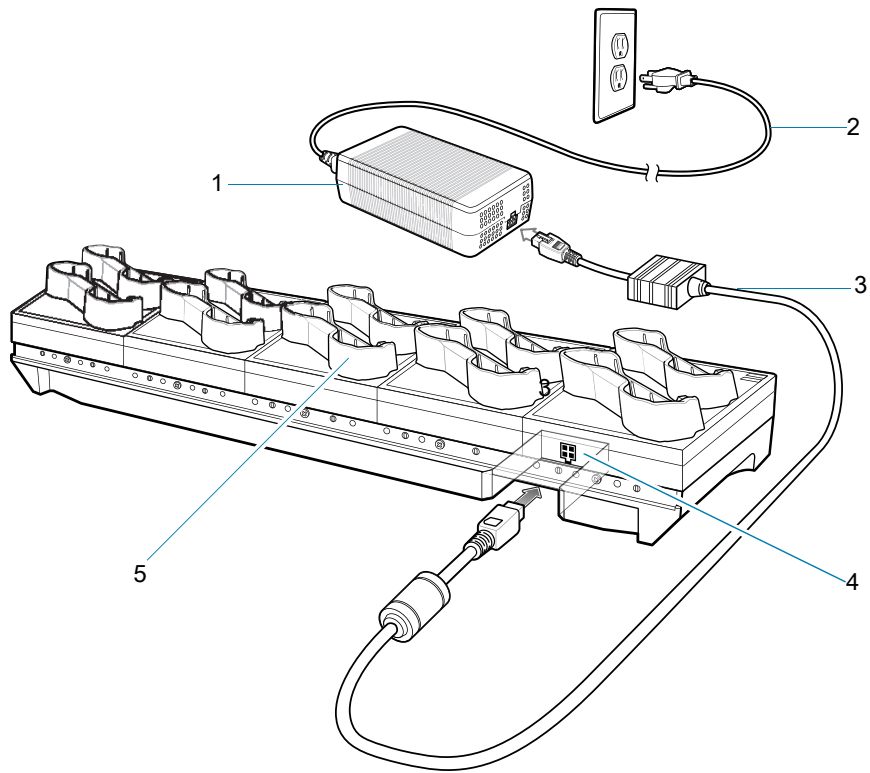

1	Power supply
2	AC line cord
3	DC line cord
4	Power input
5	Device charging slot

Charging the Device

1. If charging a device with a standard battery, insert either end of the device into the device charging slot.

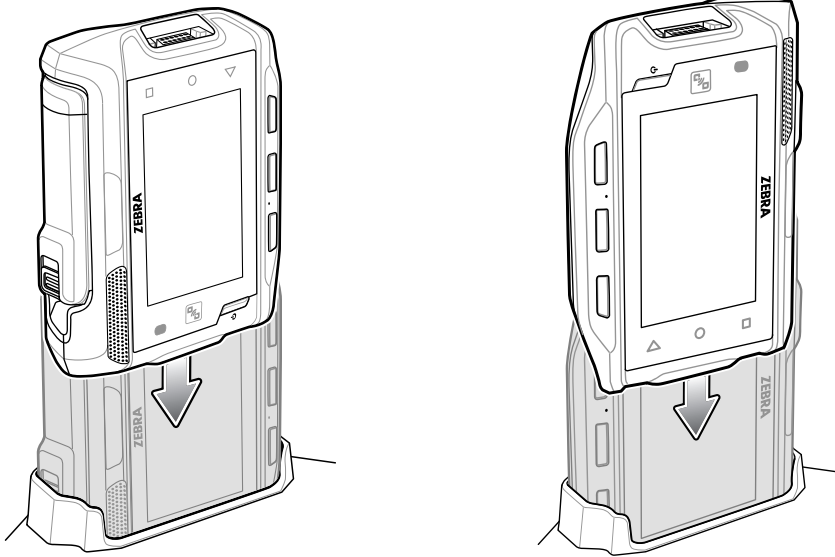

2. If charging a device with a extended battery, insert the end of the device into the device charging slot as shown below.

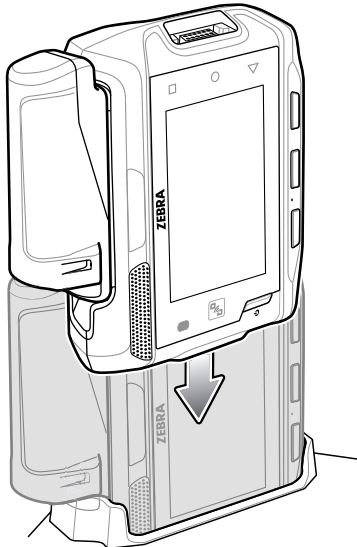

3. Ensure the device is seated properly. The device Charge LED blinks indicating charging.

5-Slot Ethernet Cradle



CAUTION: Ensure that you follow the guidelines for battery safety described in [Battery Safety Guidelines](#) on page 152.

The 5-Slot Ethernet Cradle:

- Provides 5.4 VDC (nominal) power for operating the device.
- Connects up to five devices to an Ethernet network.
- Simultaneously charges up to five devices.
- Simultaneously charges up to five spare batteries.

Figure 49 5-Slot Device Ethernet Cradle

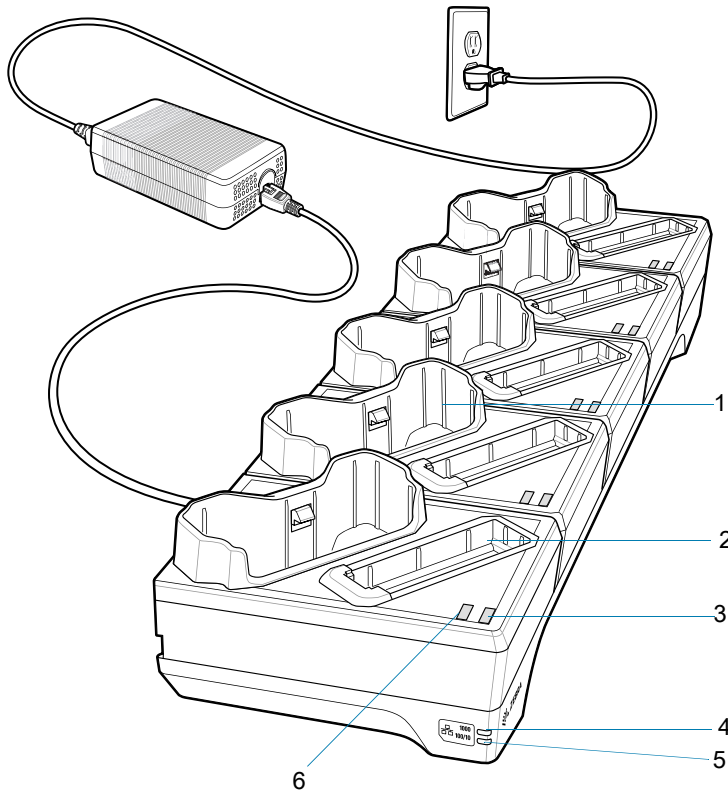

1	Device charging
2	Spare battery charging slot
3	Spare battery charging LED
4	1000 LED
5	10/100 LED
6	Device charging LED

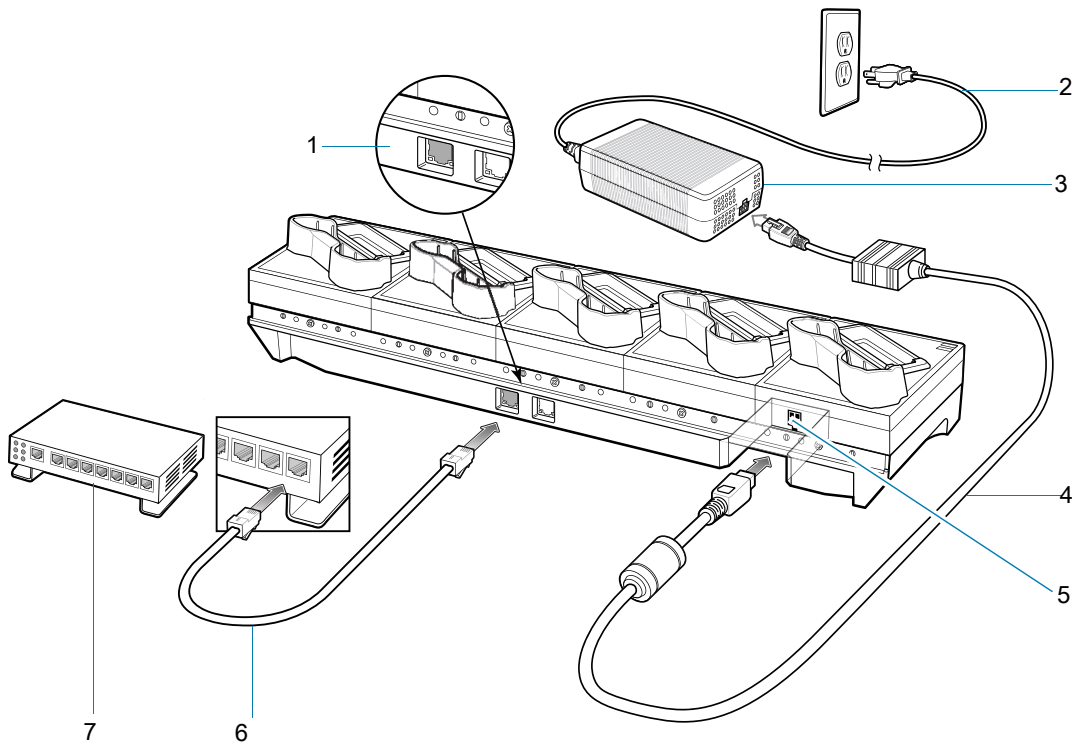

Setup

Figure 50 5-Slot Device Ethernet Cradle Setup



1	Primary Ethernet Port
2	AC line cord
3	Power supply
4	DC line cord
5	Power port
6	Ethernet cable
7	Ethernet switch

Establishing Ethernet Communication

1. Swipe down from the status bar to open the quick settings bar and then touch .
2. Touch  **Ethernet setting**.
3. Slide the Ethernet switch to the **ON** position.
4. Insert the device into a slot.
5. The  icon appears in the Status bar.
6. Touch **Eth0** to view Ethernet connection details.

Ethernet LED Indicators

There are two green LEDs on the side of the cradle. These green LEDs light and blink to indicate the data transfer rate.

Table 16 LED Data Rate Indicators

Data Rate	1000 LED	100/10 LED
1 Gbps	On/Blink	Off
100 Mbps	Off	On/Blink
10 Mbps	Off	On/Blink

Daisy-chaining Ethernet Cradles

Daisy-chain up to ten 5-Slot Ethernet cradles to connect several cradles to an Ethernet network. Use either a straight or crossover cable. Daisy-chaining should not be attempted when the main Ethernet connection to the first cradle is 10 Mbps as throughput issues will almost certainly result.

To daisy-chain 5-Slot Ethernet cradles:

1. Connect power to each 5-Slot Ethernet Cradle.
2. Connect an Ethernet cable to port 1 on the back of the first cradle and to the Ethernet switch.
3. Connect an Ethernet cable to port 2 on the back of the first cradle to port 1 on the back of the second cradle.

Figure 51 Daisy-Chaining 5-Slot Ethernet Cradles

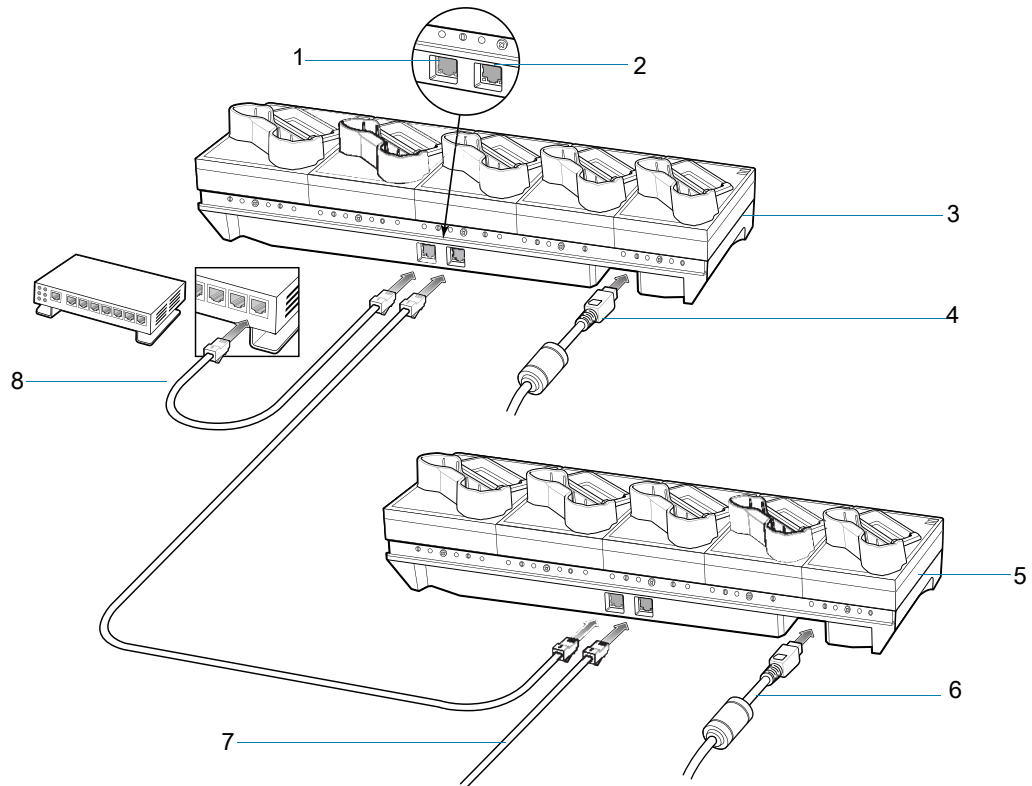

4. Connect additional cradles as described in step 2 and 3.

1	Primary port
2	Secondary port
3	First cradle
4	To power supply
5	Second cradle
6	To power supply
7	Ethernet cable to next cradle
8	To Ethernet switch



Ethernet Settings

The following settings can be configured when using Ethernet communication:

- Proxy Settings
- Static IP.

Configuring Ethernet Proxy Settings

The device includes Ethernet cradle drivers. After the device, configure the Ethernet connection:

1. Swipe down from the status bar to open the quick settings bar and then touch .
2. Touch  **Ethernet setting**.
3. Slide the switch to the **ON** position.
4. Touch  > **Advanced**.

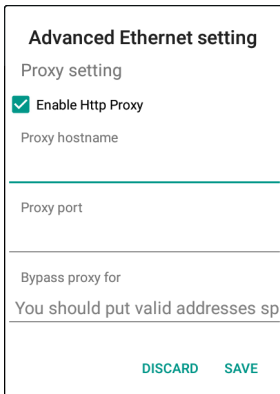

5. Touch **Enable Http Proxy**.
6. In the Proxy hostname field, enter the proxy server address.
7. In the Proxy port field, enter the proxy server port number.



NOTE: When entering proxy addresses in the Bypass proxy for field, do not use spaces or carriage returns between addresses.

8. In the Bypass proxy for text box, enter addresses for web sites that do not require to go through the proxy server. Use the separator “|” between addresses.
9. Touch **Save**.

10. Touch the Home button.

Configuring Ethernet Static IP Address

The device includes Ethernet cradle drivers. After the device, configure the Ethernet connection:

1. Swipe down from the status bar to open the quick settings bar and then touch .
2. Touch  **Ethernet setting**.
3. Slide the switch to the **ON** position.
4. Touch  > **Config**.
5. Touch **Static IP** radio button.

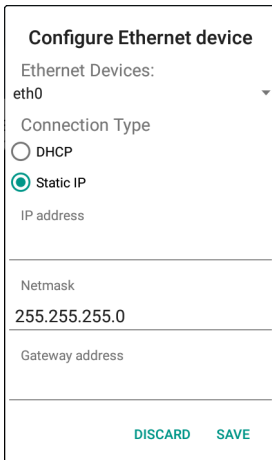

6. In the **IP address** field, enter the proxy server address.
7. If required, in the **Network** text box, enter a the network address.
8. If required, in the **Gateway address** text box, enter a gateway address for the device.
9. If required, in the **DNS address** text box, enter a Domain Name System (DNS) address.
10. Touch **Save**.
11. Touch the Home button.



LED Indicators

There are two green LEDs on the side of the cradle and on each Ethernet port. These green LEDs light and blink to indicate the data transfer rate.

Table 17 LED Data Rate Indicators

Data Rate	1000 LED	100/10 LED
1 Gbps	On/Blink	Off
100 Mbps	Off	On/Blink
10 Mbps	Off	On/Blink

Establishing Ethernet Connection

1. Swipe down from the status bar to open the quick settings bar and then touch .
2. Touch  **Ethernet setting**.
3. Slide the **Ethernet** switch to the **ON** position.

The  icon appears in the **Status** bar.

4. Touch **Ethernet Information** to view Ethernet connection details.

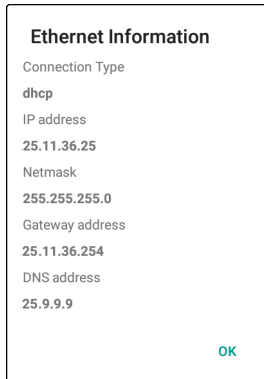

5. Touch **OK** to close dialog box.

4-Slot Spare Battery Charger



CAUTION: Ensure that you follow the guidelines for battery safety described in [Battery Safety Guidelines](#) on page 152.

The 4-Slot Battery Charger charges up to four spare batteries.

Figure 52 4-Slot Battery Charger Power

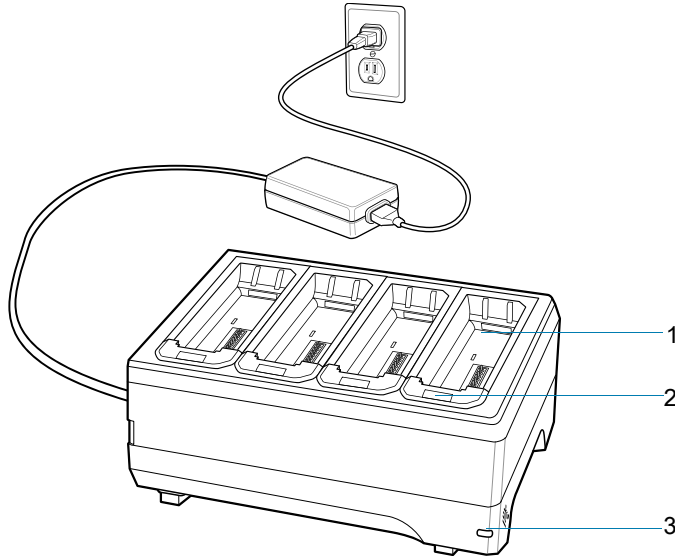

1	Spare battery charging slot
2	Battery charging LEDs (4)
3	Power LED

Setup

Figure 53 4-Slot Battery Charger Power Setup

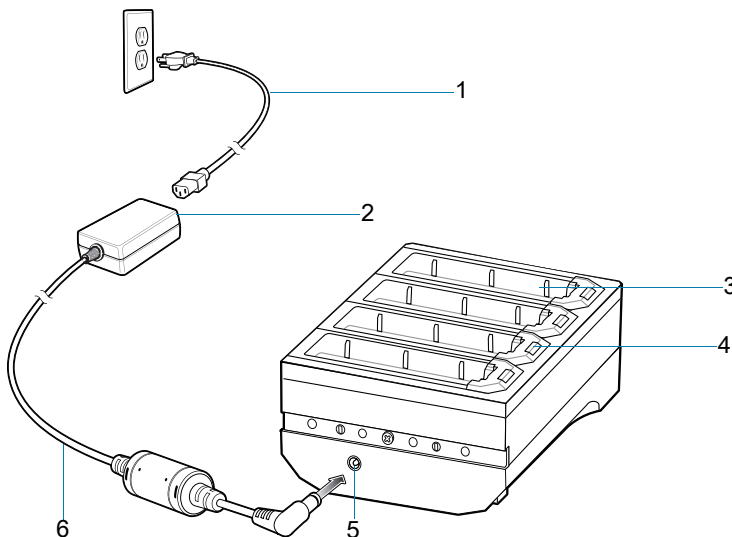

1	AC line cord
2	Power supply
3	Spare battery charging slot
4	Spare battery charging LED
5	Input power
6	DC line cord

Charging the Spare Battery

To charge the spare battery:

1. Insert the battery into a battery slot.
2. Gently press down on the battery until it snaps into place.

Figure 54 Insert Standard Battery into Slot

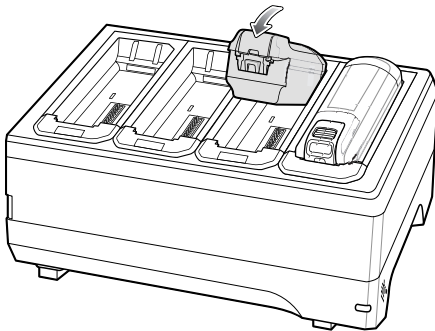
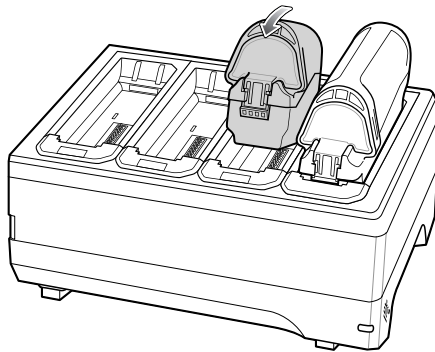

Figure 55 Insert Extended Battery into Slot



Battery Removal

To remove the battery, press the battery release latch toward the end of the battery and lift the battery out of the battery slot.

20-Slot Spare Battery Charger



CAUTION: Ensure that you follow the guidelines for battery safety described in [Battery Safety Guidelines](#) on page 152.

The 20-Slot Battery Charger charges up to 20 spare batteries.

Figure 56 20-Slot Battery Charger

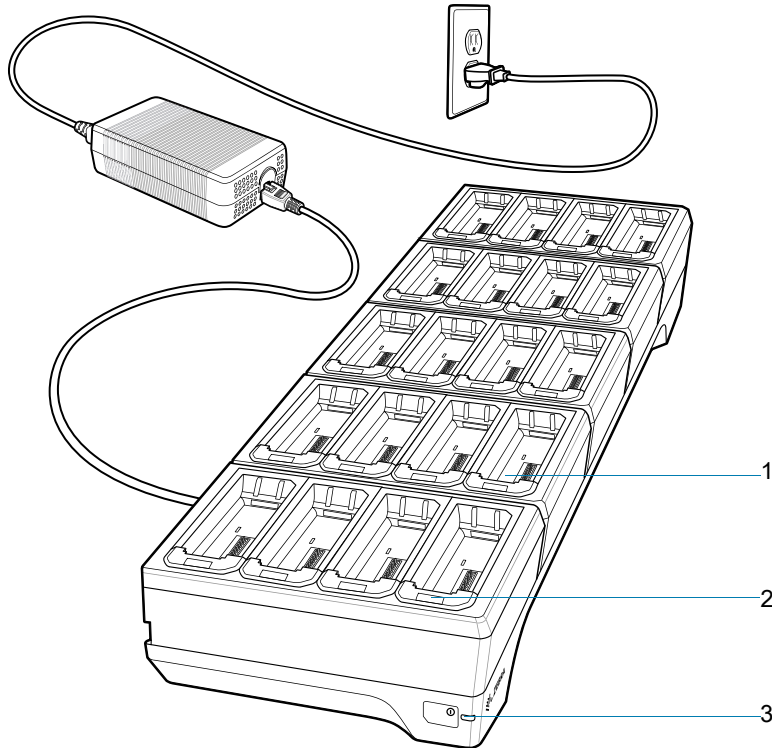

1	Spare battery charging slot
2	Battery charging LEDs (20)
3	Power LED

Setup

Figure 57 20-Slot Battery Charger

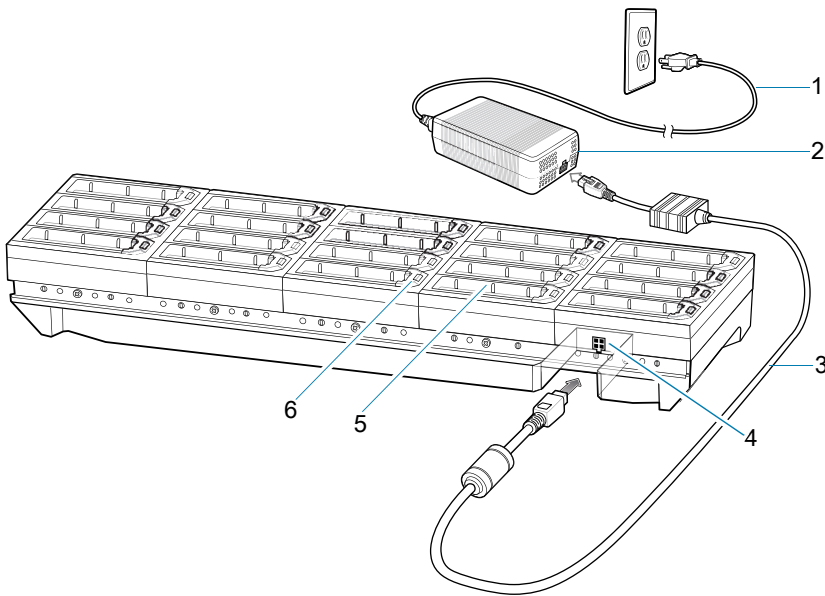

1	AC line cord
2	Power supply
3	DC line cord
4	Input power
5	Spare battery charging slot
6	Spare battery charging LED

Charging the Spare Battery

1. Insert a spare battery into the spare battery slot.
2. Gently press down on the battery until it snaps into place.

Figure 58 Insert Battery into Cradle

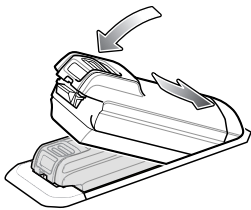
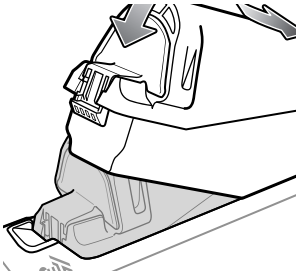

Figure 59 Insert Extended Battery into Cradle



3. Ensure the battery is seated properly. The Spare Battery Charging LED blinks indicating charging.

Battery Removal

To remove the battery, press the battery release latch toward the end of the battery and lift the battery out of the battery slot.

USB and Charging Cable



CAUTION: Ensure that you follow the guidelines for battery safety described in [Battery Safety Guidelines](#) on page 152.

The USB and Charging cable connects to either interface connector on the device. When attached to the device, allows the device to transfer data to a host computer and provide power for charging the device.

Figure 60 USB and Charging Cable

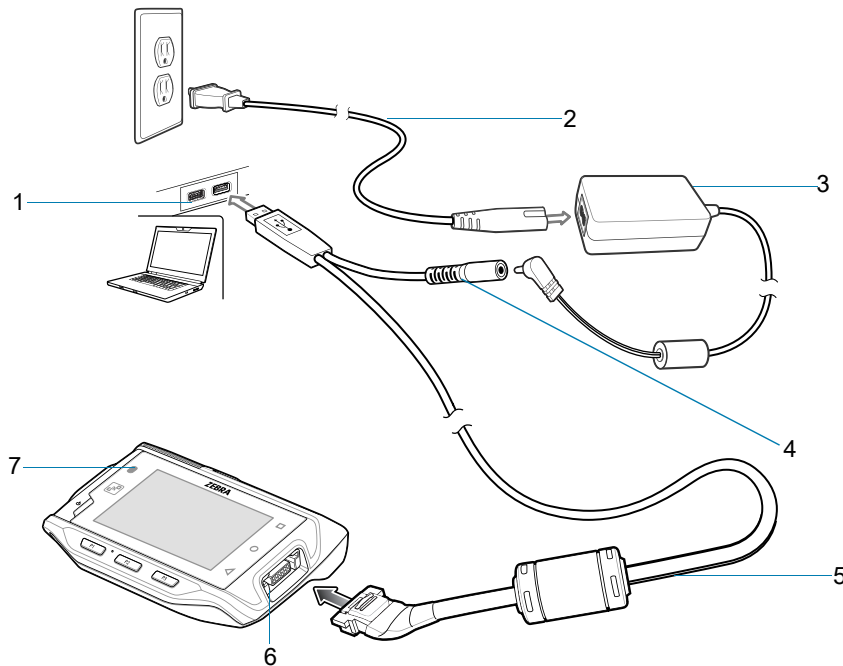

1	Host computer
2	AC line cord
3	Power supply
4	Power connector

5	USB cable connector
6	Interface connector
7	USB LED indicator

Attaching the USB and Charging Cable

1. Connect the connector to the device interface connector.

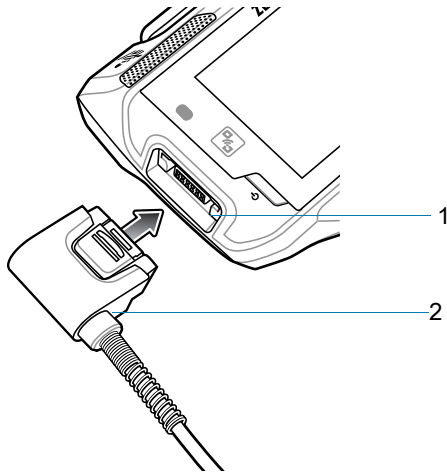

1	Interface connector
2	Cable connector

2. Attach the USB connection to the host computer.

Removing the USB and Charging Cable

To remove the USB and Charging cable:

1. Press the release level toward the cable.
2. Rotate the adapter toward the front of the device and remove.

Keypad

Figure 61 Keypad

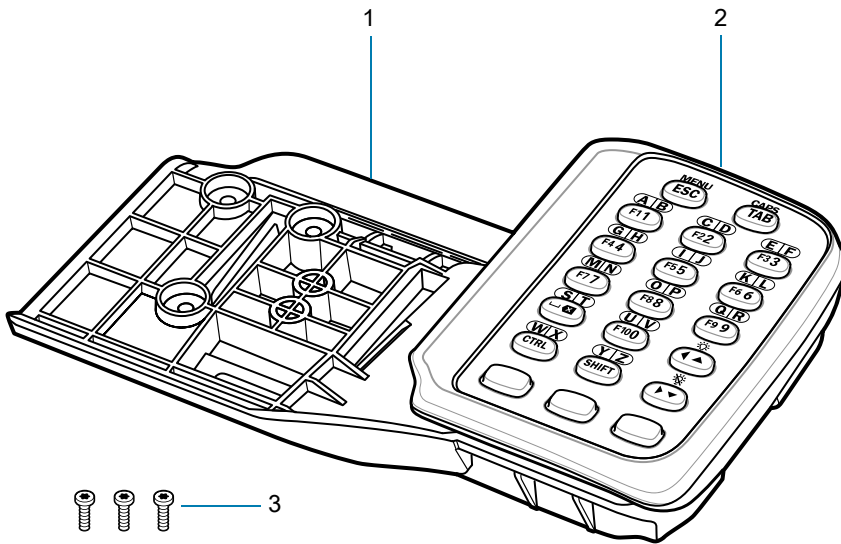

1	Keypad Mount
2	Device Keypad
3	Installation Screws

Installing the Keypad

1. Using a T6 Torx screwdriver, remove the screws from the cleat on the back of the device.

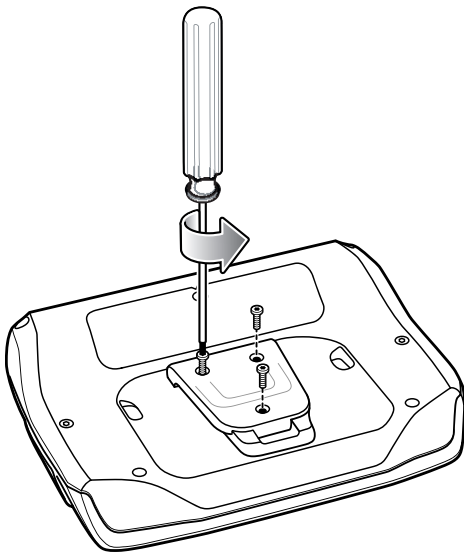

2. Lift the cleat from the back of the device.

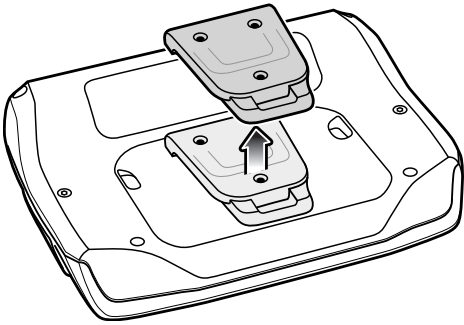

3. Slide the keypad mount onto the device.

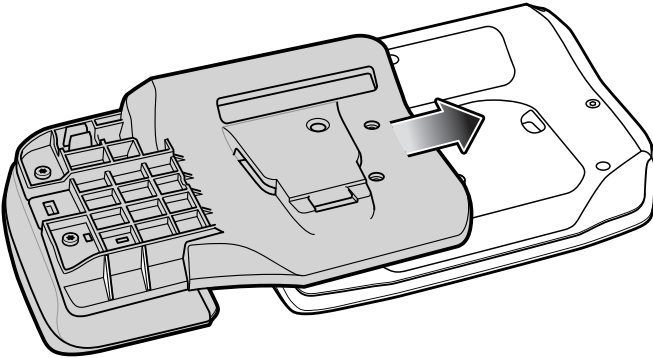

4. Using a T6 Torx screwdriver, secure the keypad mount to the device with the three screws, and torque to 2kgf-cm or 1.73lbf-in.

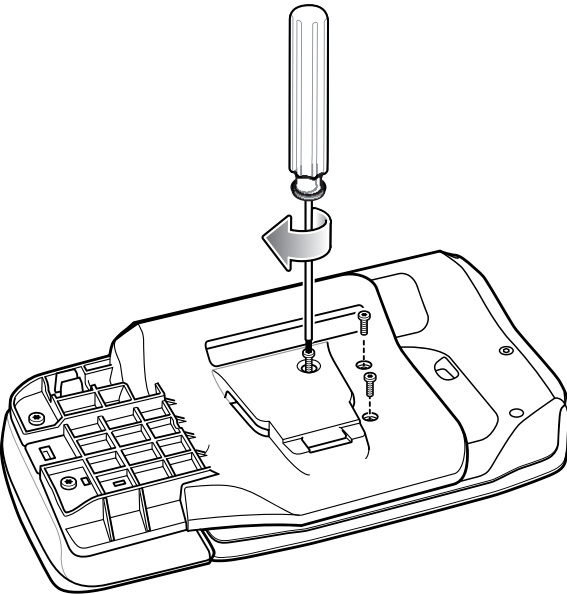

Replacing the Keypad Mount

To replace the keypad mount:

1. Using a T8 Torx screwdriver, remove the two screws that connect the keypad to the mount.

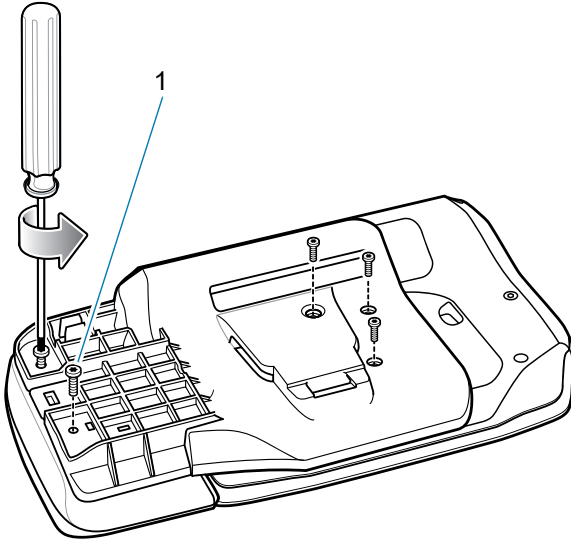

1	Screws (2)
---	------------

2. Using a T6 Torx screwdriver, remove the three screws that connect the keypad mount to the device.

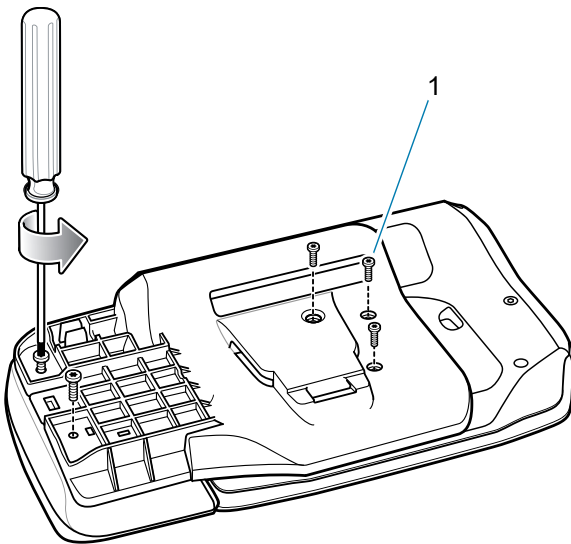

1	Screws (3)
---	------------

3. Slide the mount off of the device.

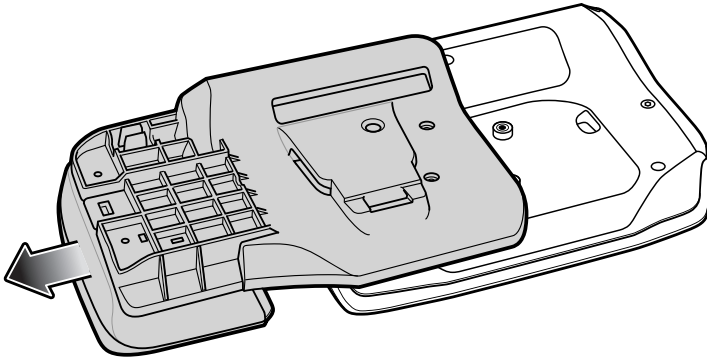

4. Press and hold the latch under the keypad.

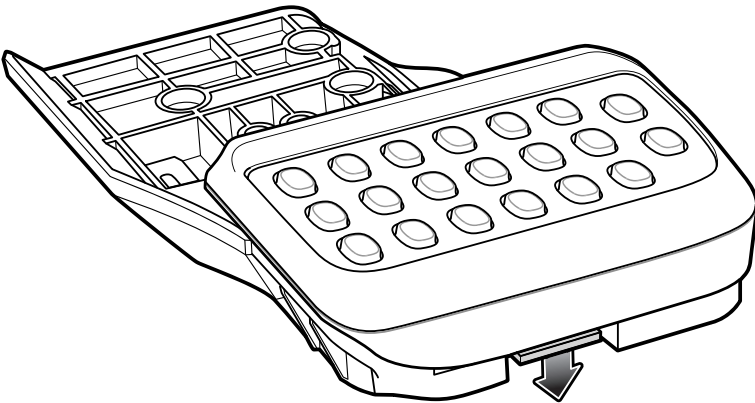

5. Slide the keypad off the mount.

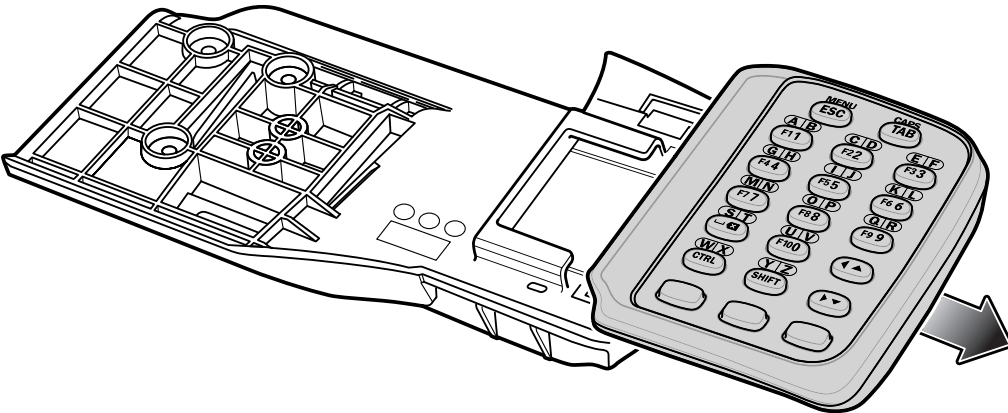

6. Slide the keypad onto the new mount. Ensure the keypad snaps securely onto the mount.

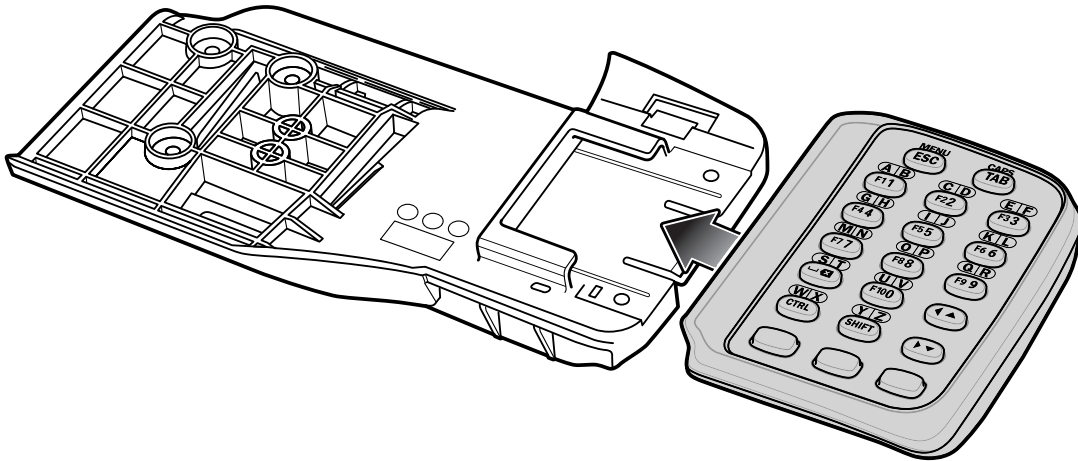

7. Slide the mount onto the device.

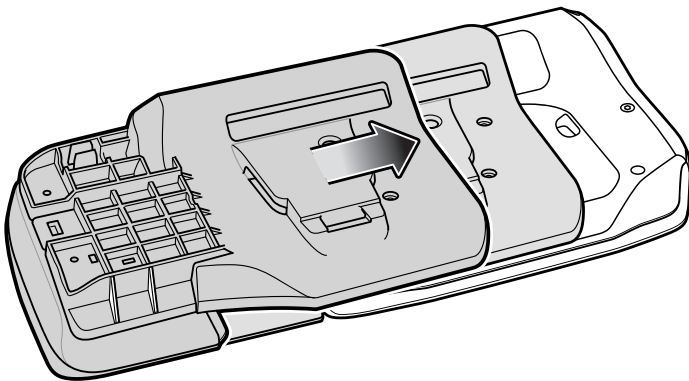

8. Using a T8 Torx screwdriver, secure the keypad mount to the device with the two screws, and torque to 2kgf-cm or 1.73lbf-in.

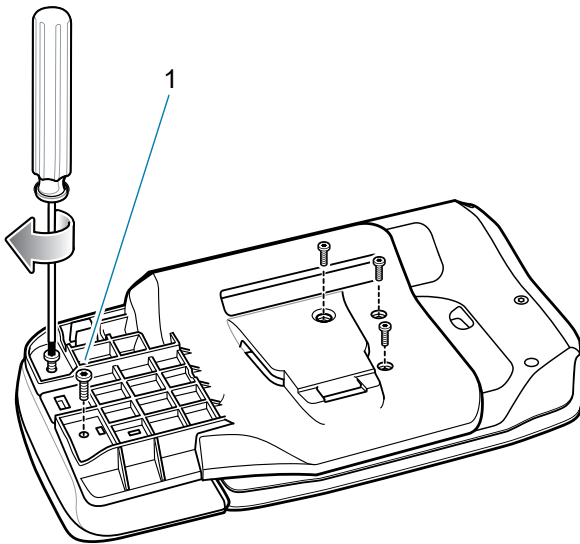

1	Screws (2)
---	------------

- Using a T6 Torx screwdriver, secure the keypad mount to the device with the three screws, and torque to 2kgf-cm or 1.73lbf-in.

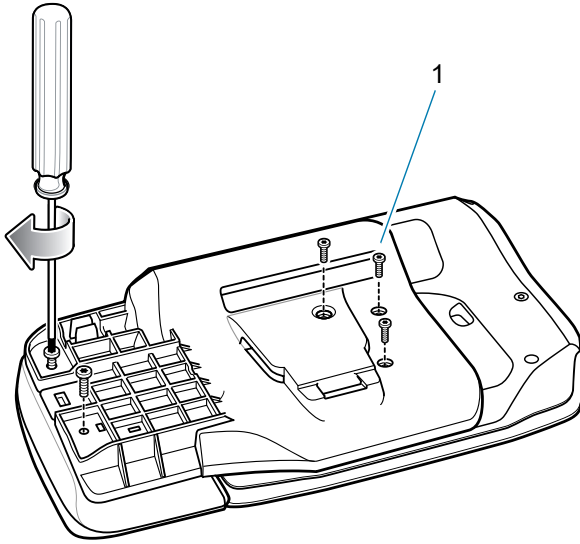

1	Screws (3)
---	------------

Hip Mount

The hip mount allows the user to mount the device on the belt for use in voice picking applications. An RS4000 or RS5000 scanner with an extended cable, a wired headset or the RS6000 Hands-free Bluetooth Imager is required when using the hip mount.

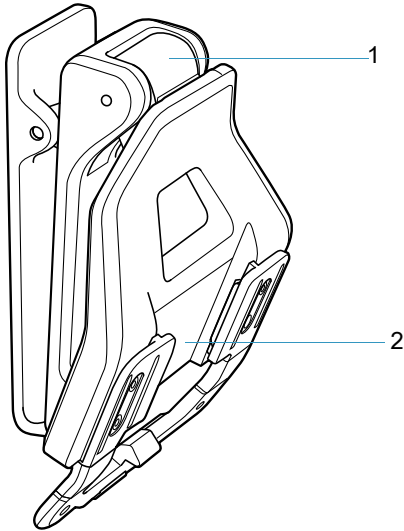

1	Hinge
2	Mounting bracket

1. Attach the Hip Mount to belt.
2. Align the cleat on the device with the mounting bracket on the Hip Mount.
3. Slide the device into the hip mount.

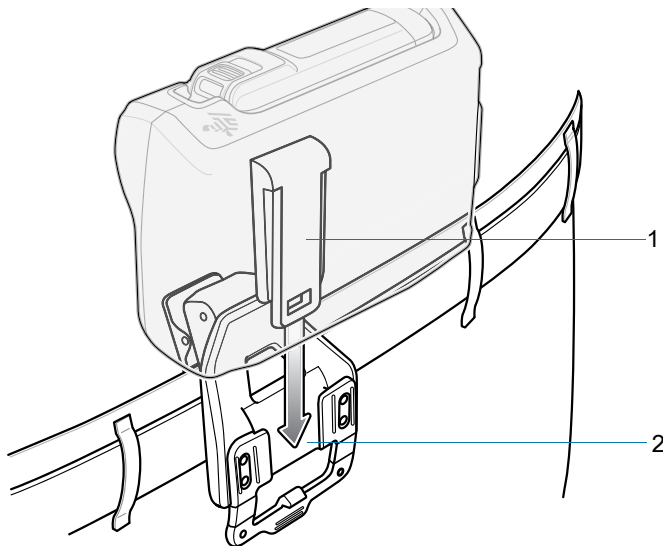

1	Cleat
2	Mounting bracket

4. Connect RS4000, RS5000 or headset to the device.

The Hip Mount provides a hinged bracket so the user can easily view the display by lifting the device.

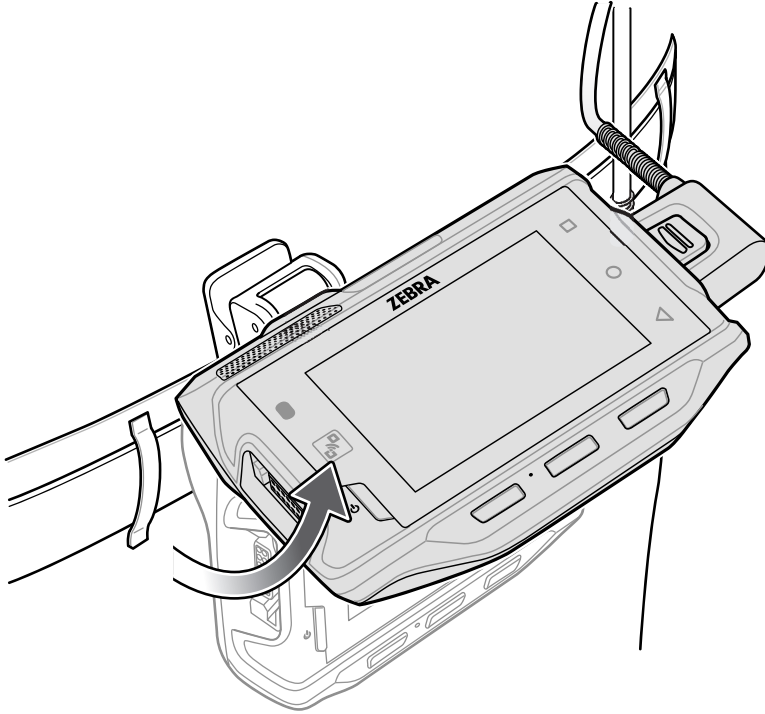

Routing an Extended Cable Scanner

When using an RS4000 or RS5000 scanner with the device mounted on the hip, the extended cable version is required.

Zebra offers for sale cable clips, which attach to clothing and hold the scanner cable so that the cable does not interfere with the user. The cable clips are similar to badge clips and can be purchased at any office supply store as well.

Figure 62 Routing RS4000 Scanner Cable from Hip to Hand

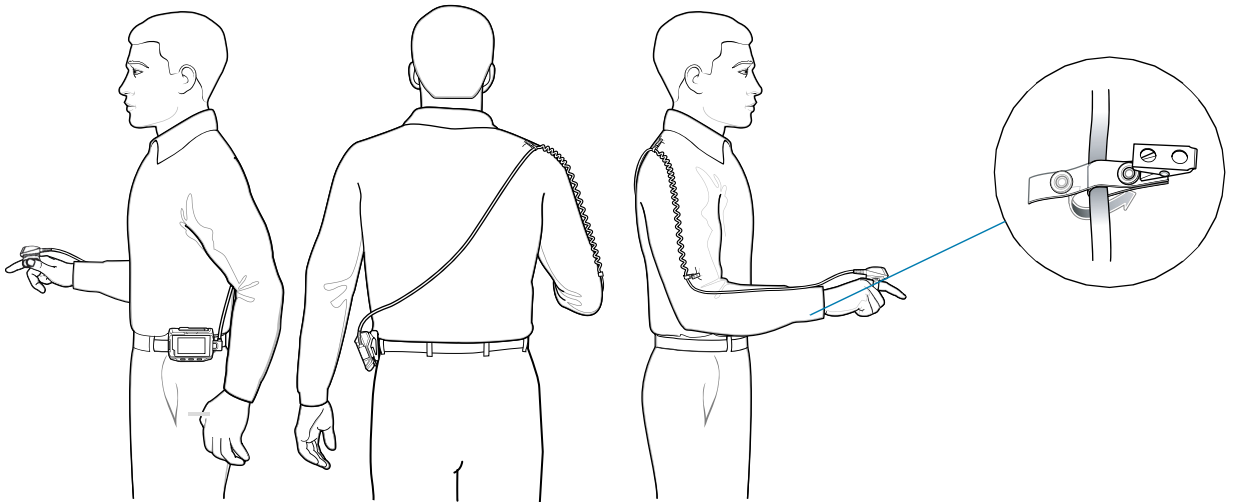

Quick Disconnect Audio Cables

The Quick Disconnect Audio Adapter snaps into either interface connector. When attached to the device, the Quick Disconnect Audio Adapter allows a user to connect a wired headset to the device.

Figure 63 Long Audio Cable

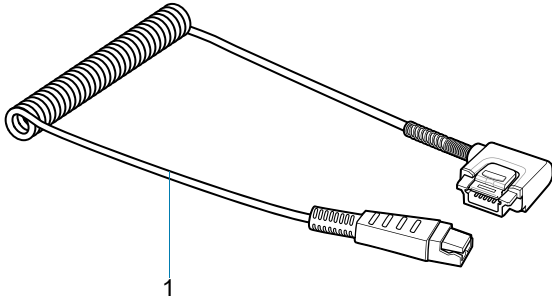

1	Long audio cable
---	------------------

Figure 64 Short Audio Cable

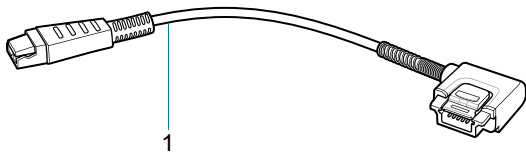

1	Short audio cable
---	-------------------

Attaching the Audio Adapter

1. Align the tabs on the Audio Adapter with the slots on the device.
2. Rotate the Adapter toward the back of the device until the Adapter snaps onto the device.

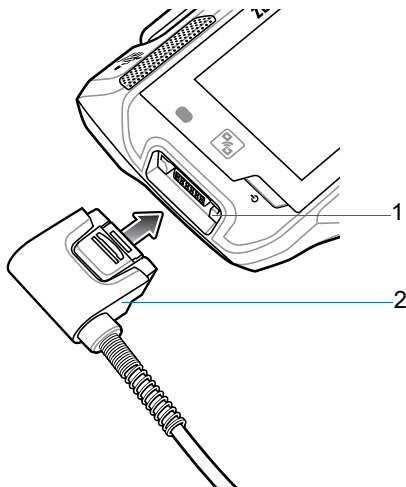

1	Interface connector
2	Cable connector

Connecting the Audio Cable to a Headset

Figure 65 Short Quick Disconnect Audio Cable Connection to Headset

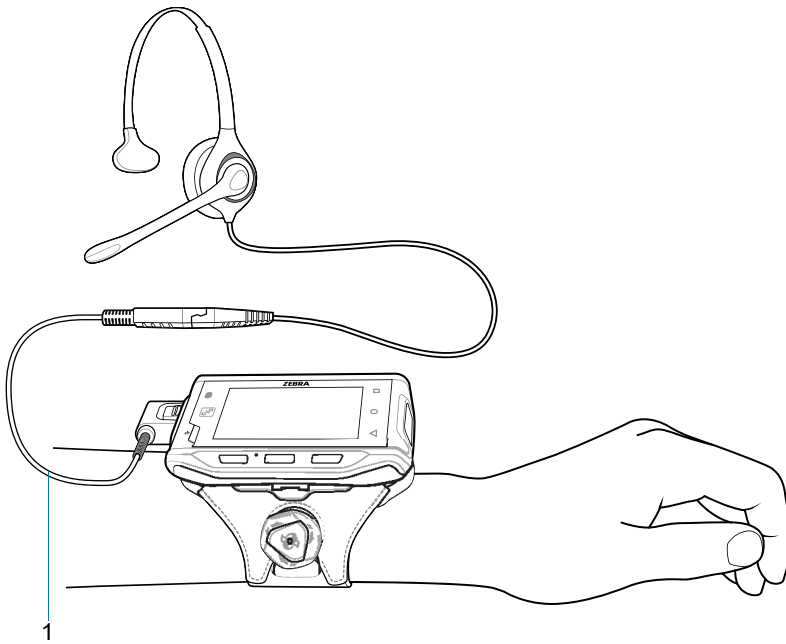

1	Short audio cable
---	-------------------

Figure 66 Long Quick Disconnect Audio Cable Connection to Headset

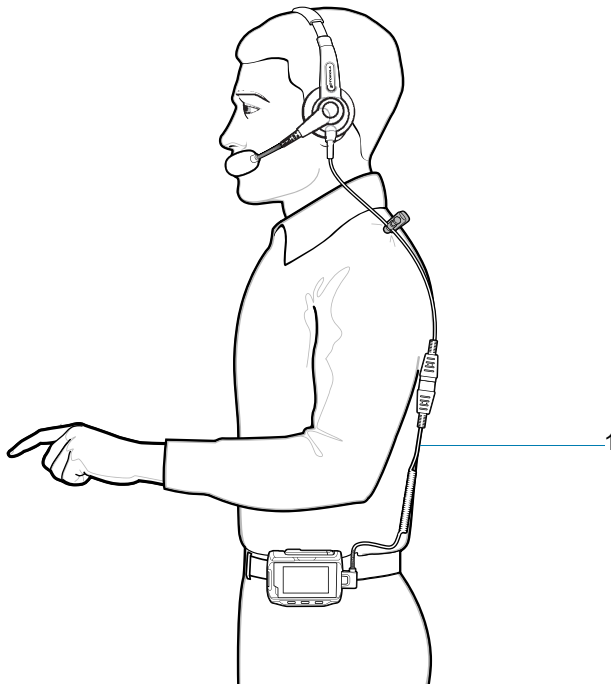

1	Long audio cable
---	------------------

Removing the Audio Adapter

To remove the Audio Adapter:

1. Press the release lever toward the cable.
2. Rotate the adapter toward the front of the device and remove.

Vibrator Cable

Use the vibrator cable to provide a touch notification to a user in noisy environments.

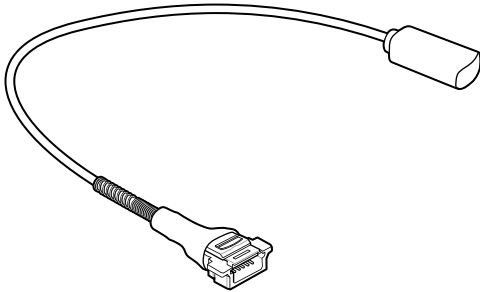

1. Connect the cable to the interface connector on the device.
2. Slide the vibrator end between the wrist mount strap and arm.

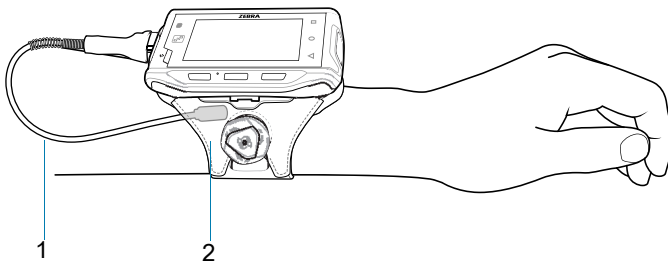

1	Vibrator cable
2	Wrist mount

When an application generates a notification, the vibrator vibrates notifying the user.

RS4000 Scanner

To connect the RS4000 scanner to the device:



NOTE: There are two scanner configurations available. The short cable configuration connects the scanner to the device mounted on the arm. The extended cable configuration connects the scanner to the device mounted on the hip.

1. Connect the scanner interface cable to the device interface connector. If the device is mounted on the arm, connect the cable to the interface connector closest to the wrist.

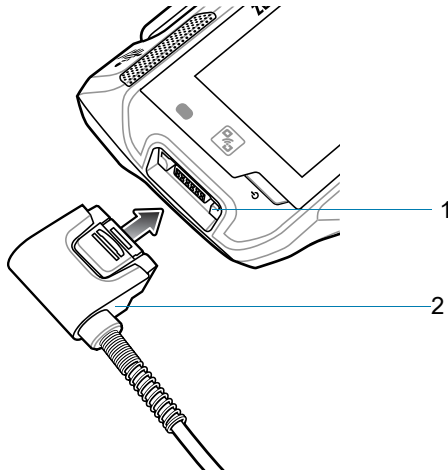

1	Interface connector
2	Cable connector

2. If using the extended cable configuration, route the scanner cable up to the shoulder and down to the hand that the scanner mounts on. Attach two cable clips to clothing and secure cable to cable clip.

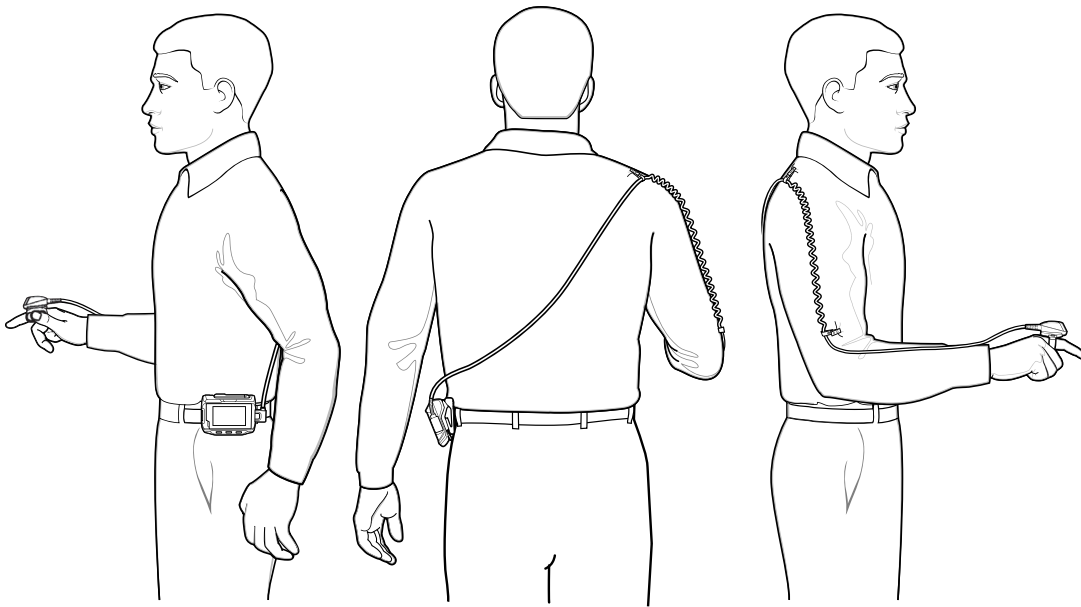

3. Rotate the trigger assembly to the correct position for the hand that the scanner mounts to.

4. Slide the scanner onto the index finger with the scan trigger next to the thumb.

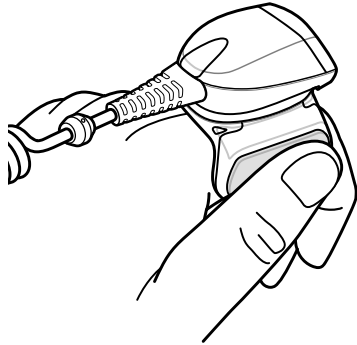

5. Tighten the finger strap.

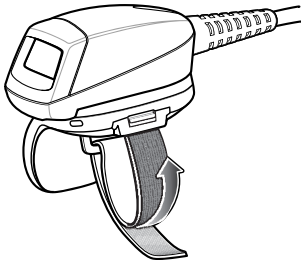

6. After connecting the scanner, warm boot the device. See [Resetting the Device on page 158](#) for information on performing a warm boot.

RS5000 Imager

To connect the RS5000 imager to the wearable terminal:

1. If using the device wearable terminal, remove the connector cap.
2. Connect the RS5000 interface cable to the wearable terminal interface connector. If connecting to a wrist mounted wearable terminal, connect to the interface connector closest to the wrist.

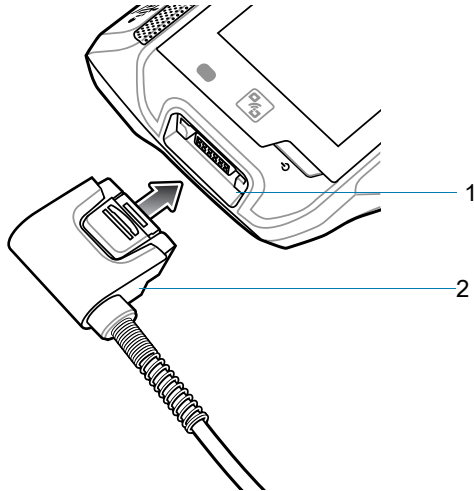

1	Interface connector
2	Scanner cable connector

3. If using the extended cable configuration, route the scanner cable up to the shoulder and down to the hand that the scanner mounts on. Attach two cable clips to clothing and secure cable to cable clip.

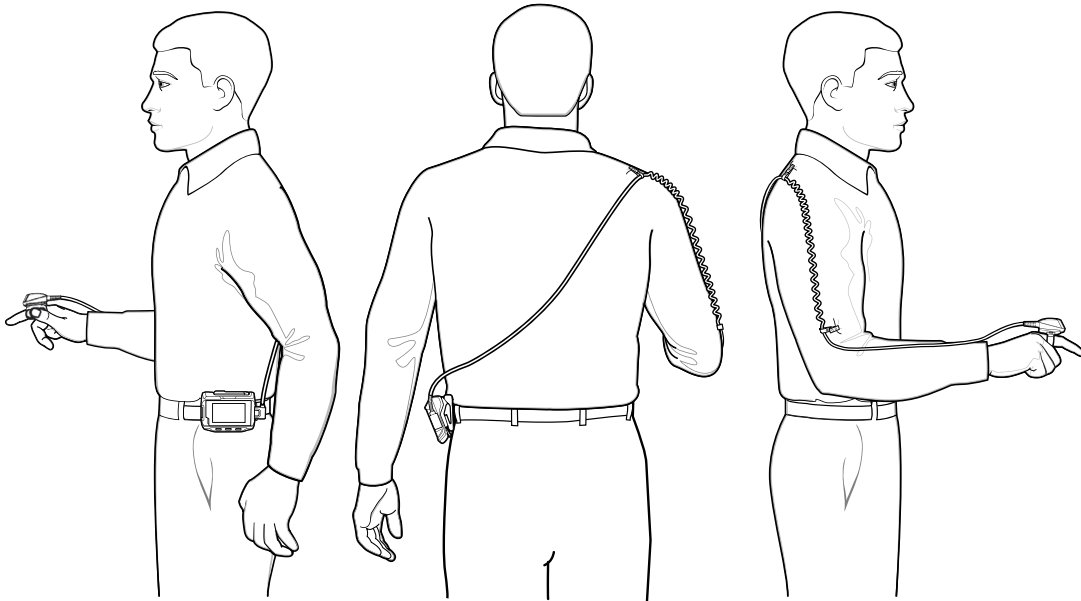

4. Rotate the trigger assembly to the correct position for the hand that the imager mounts to.

5. Slide the RS5000 onto the index finger with the scan trigger next to the thumb.

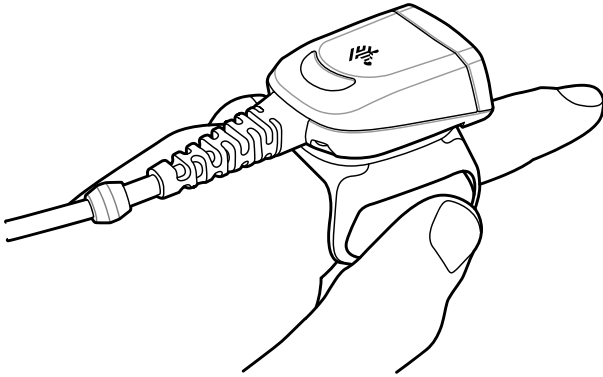

6. Tighten the finger strap.

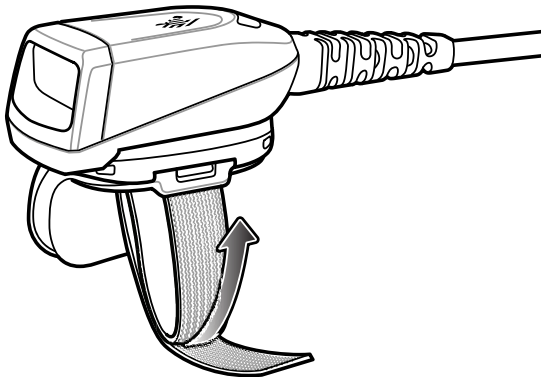

7. Soft boot the wearable terminal. See [Resetting the Device on page 158](#) for information on performing a soft boot.

5-Slot Cradle Rack Installation

Use the Rack/Wall Mount Bracket to mount a 5-slot cradle on a rack. When installing on a rack, first assemble the bracket and cradles/chargers and then install the assembly on the rack.

1. Place the power supply in bottom tray.
2. Connect AC line cord to power supply.
3. Connect DC line cord to power supply.
4. Secure power supply and cables to bottom tray with tie wraps.



NOTE: Ensure tie wrap buckle is on side of power supply. Tie wrap buckle on top of power supply interferes with top tray.

5. Route cables through cable slots.

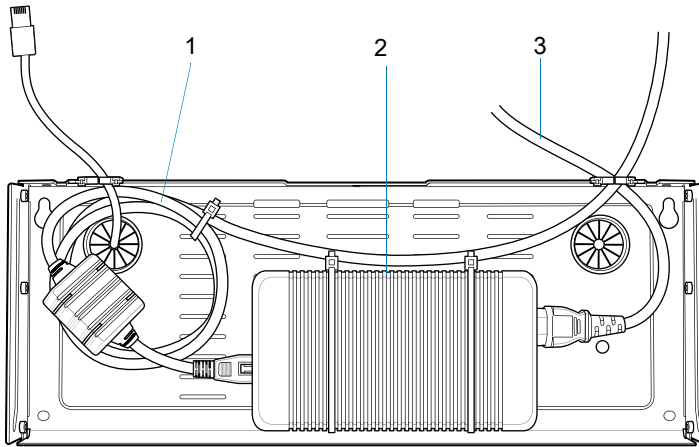

1	DC line cord
2	Power supply
3	AC line cord

6. Secure four M2.5 studs to top tray as shown.

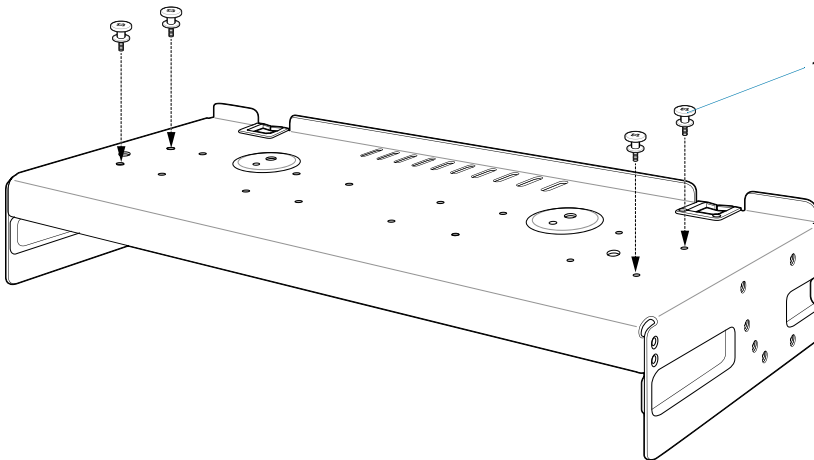

1	Studs (4)
---	-----------

7. Align and install 5-Slot cradle onto studs of top tray.

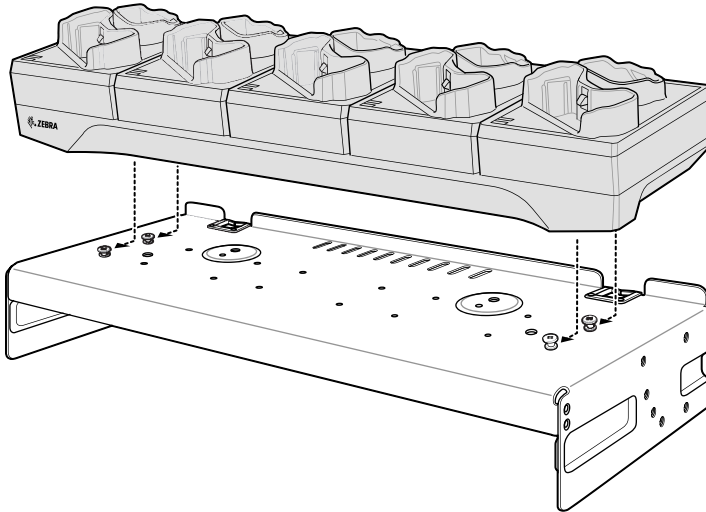

8. Secure cradle to top tray with two M2.5 safety screws.

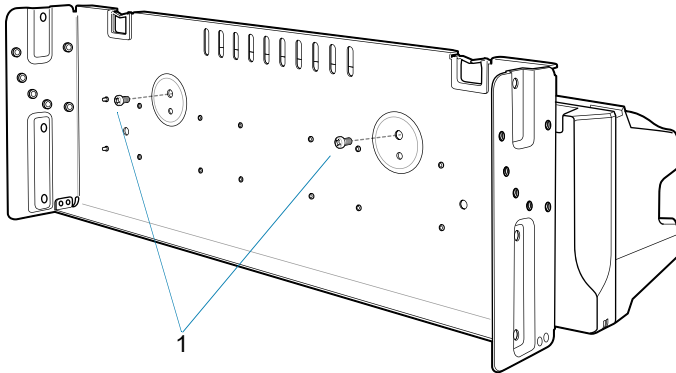

1	Safety screws (2)
---	-------------------

9. Slide top tray onto bottom tray.

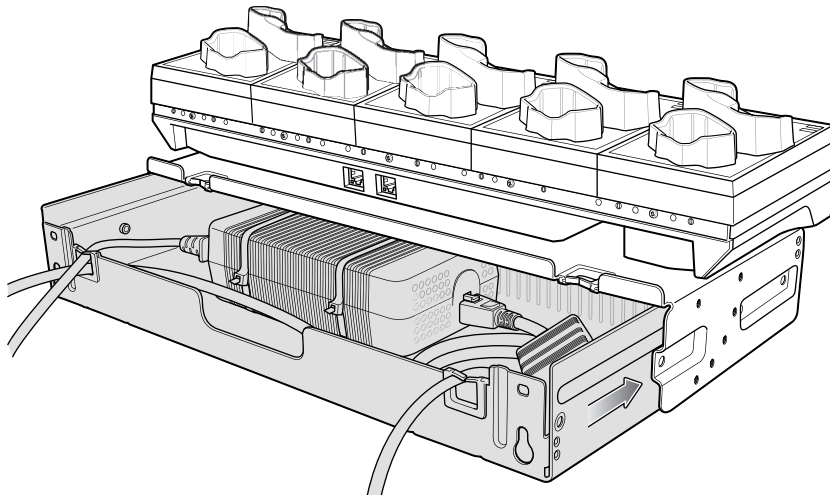

10. Connect cables to cradle.

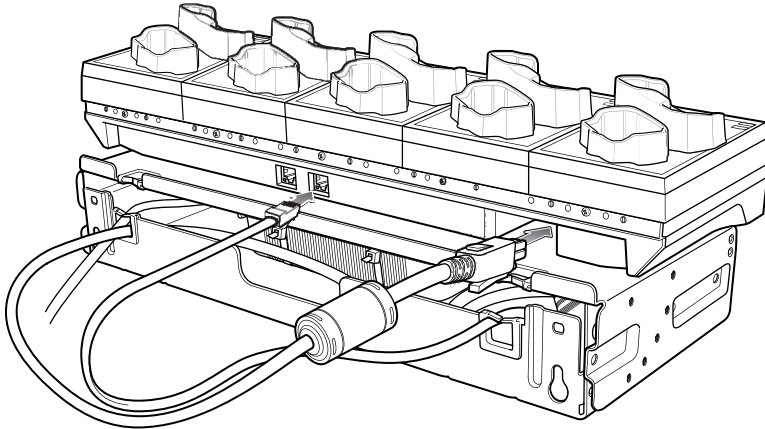

11. Secure top tray to bottom tray with 4 M5 screws (two on each side).

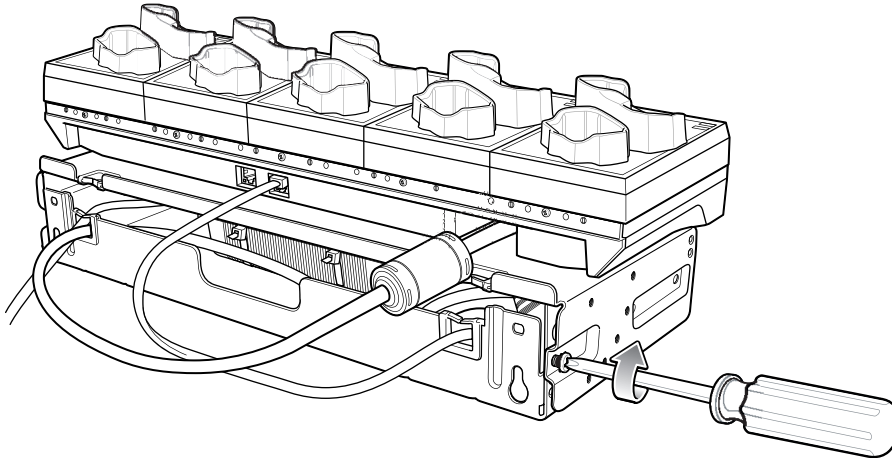

See [Rack Mount Installation on page 135](#) for installing the bracket assembly onto a rack.

4-Slot Battery Chargers Rack Installation

Use the Rack/Wall Mount Bracket to mount four 4-Slot Battery Chargers on a rack. When installing on a rack, first assemble the bracket and chargers and then install the assembly on the rack.

1. Place one power supply horizontally in bottom tray.
2. Place one power supply vertically in bottom tray.
3. Connect AC line cords to power supplies.
4. Connect DC line cords to power supplies.
5. Secure power supplies and cables to bottom tray with tie wraps.
6. Route cables through cable slots.

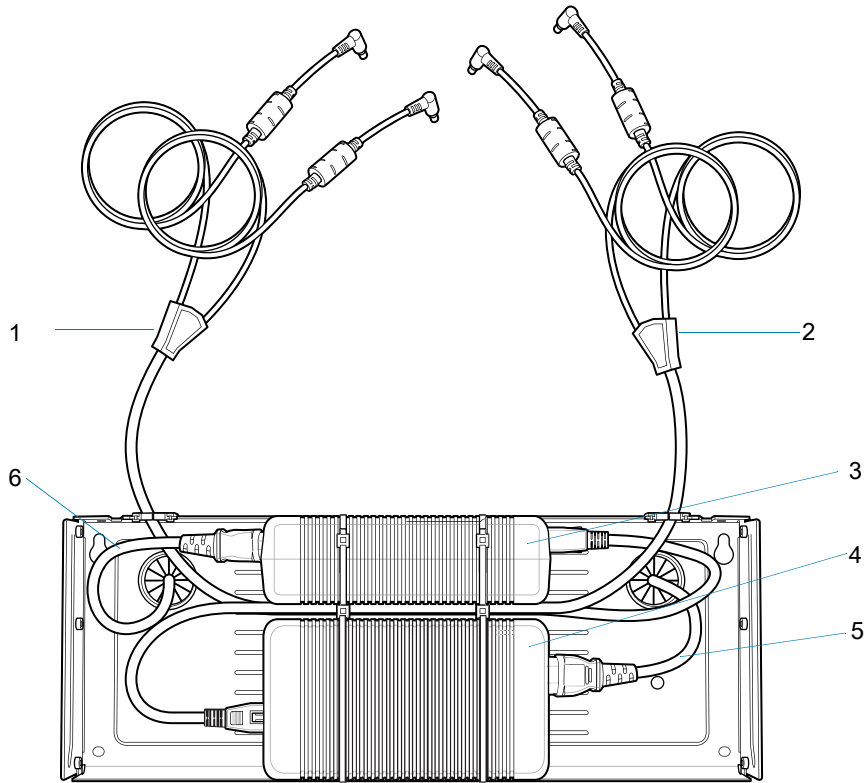

1	DC Y cable 1
2	DC Y cable 2
3	Power supply 1
4	Power supply 2
5	AC line cord 2
6	AC line cord 1

7. Slide top tray onto bottom tray until top tray touches vertical power supply.

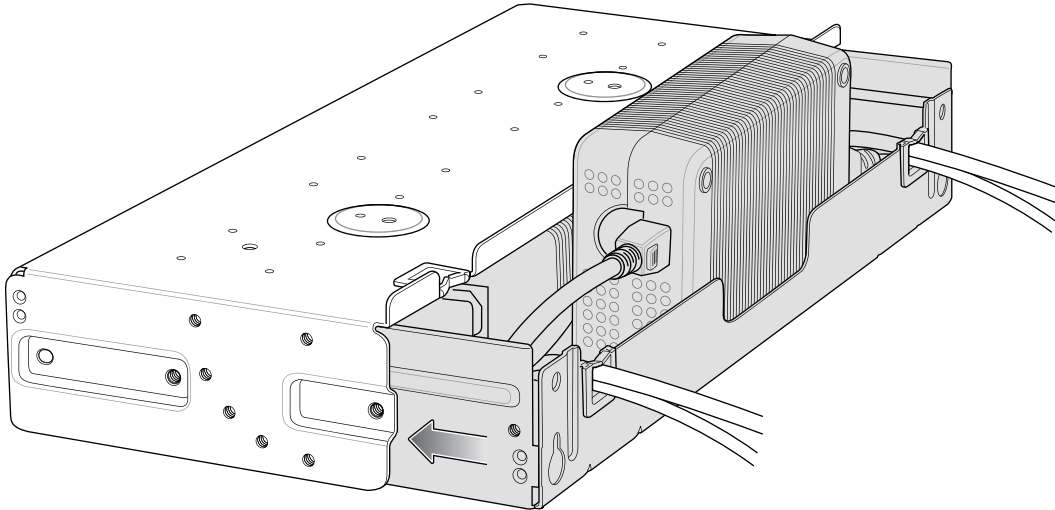

8. Install 16 M2.5 studs onto top tray as shown below.

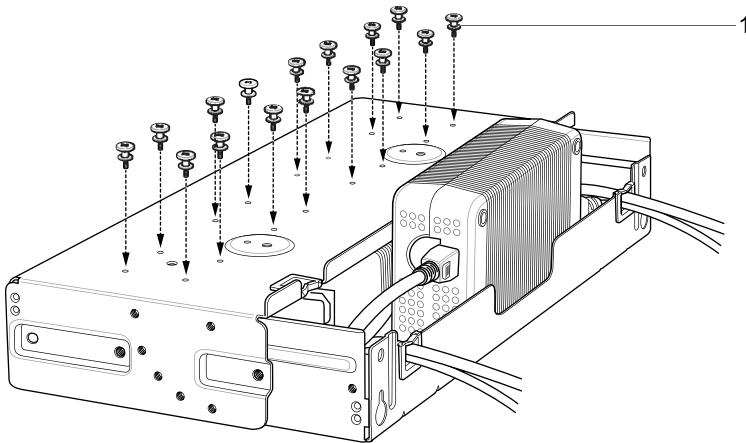

1	Studs (16)
---	------------

9. Align and install 4-Slot Battery Charger onto four studs.

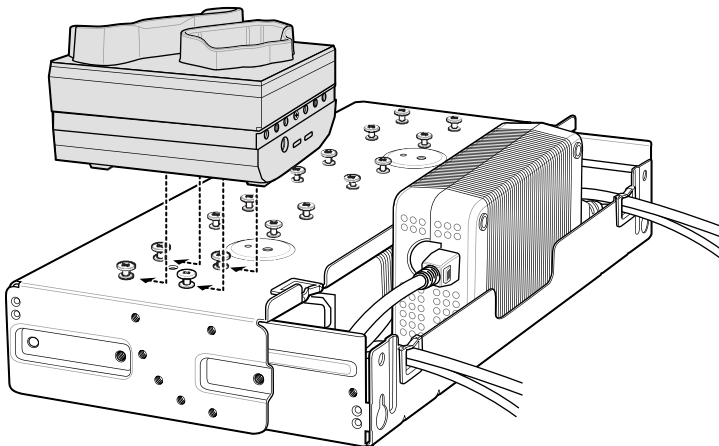

10. Connect DC Y cables to four 4-Slot Battery Chargers.

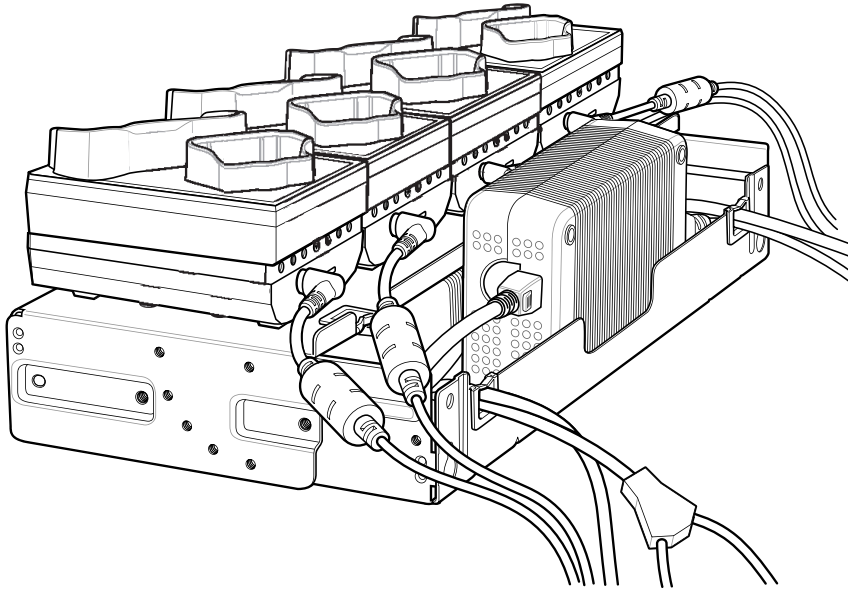

11. Secure top tray to bottom tray with four M5 screws (two on each side).

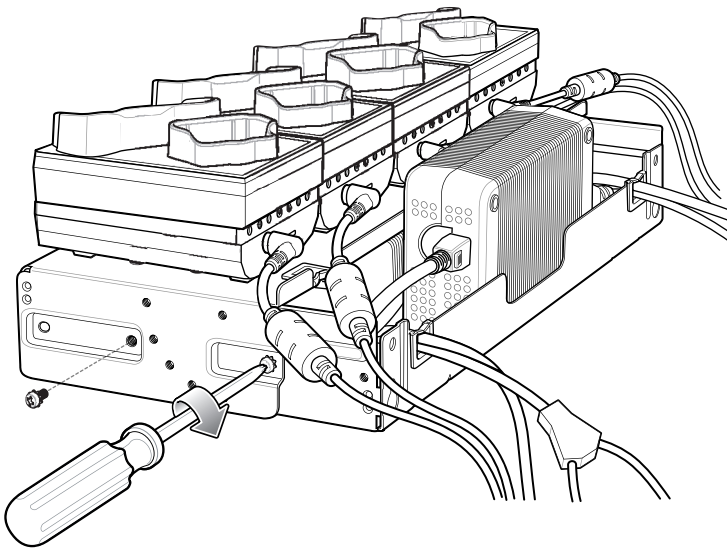

Rack Mount Installation



NOTE: Use screws provided with rack system. Refer to the rack user documentation for instructions.

1. Secure mounting brackets to both sides of top tray with four M5 screws (two on each side). For 5-Slot cradles, position the flange for vertical installation. For 4-Slot Battery Chargers, position the flange for 25° installation.

Figure 67 Flange Vertical Position (5-Slot Cradles)

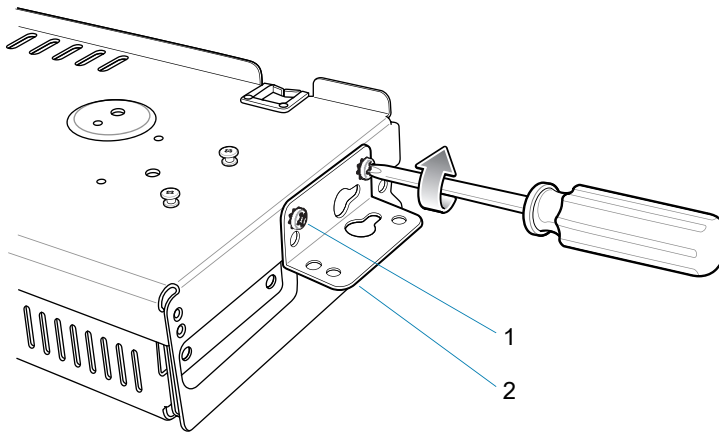

1	Top screw hole
2	Flange

Figure 68 Flange 25° Position (4-Slot Battery Chargers)

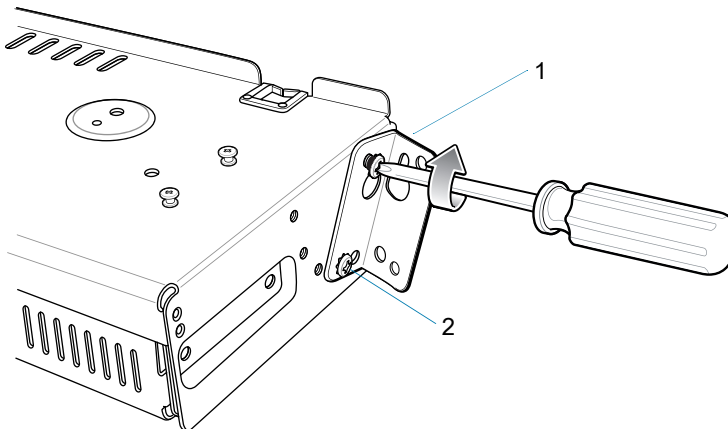

1	Flange
2	Fourth screw hole

2. Install two rack system screws for top of mounting brackets. The screw heads should protrude half way from the rail.

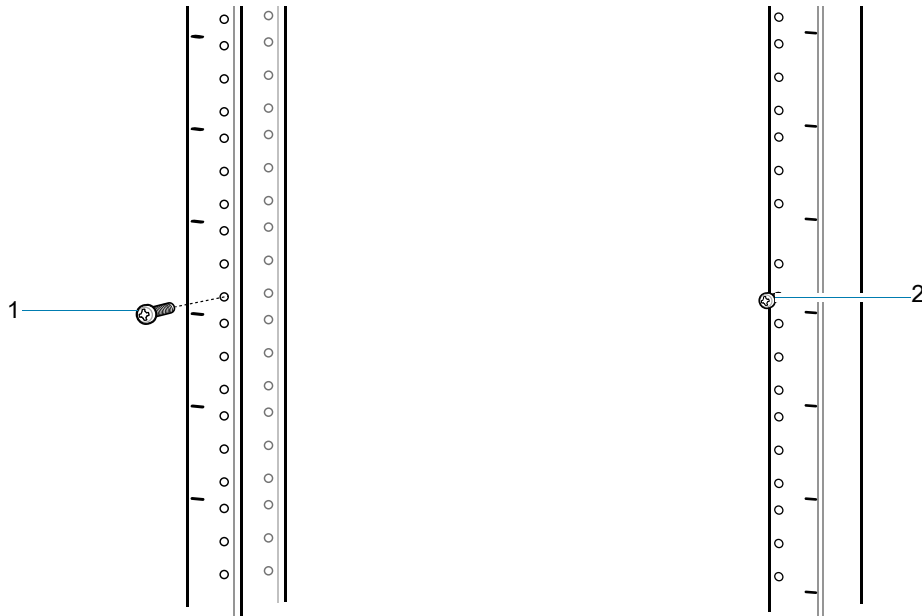

1	Rack screw
2	Rack screw

3. Align the mounting bracket's top mounting key holes with the screws.
4. Place the brackets on the screws.

Figure 69 Secure Bracket to Rack (Vertical Position Shown)

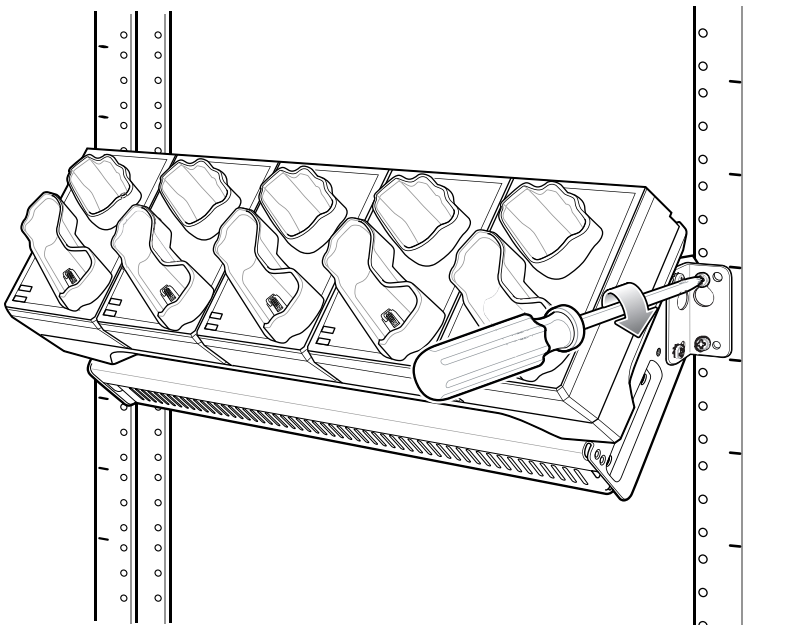

5. Secure the top screws.
6. Install bottom screws and tighten screws.
7. Route cables and connect to power source.



CAUTION: Installer should ensure that all building codes are followed when connecting the power supplies to an AC power source.

While installing the brackets, power supplies and cables:

- Use tie wraps to secure cables to the bracket and rails.
- Coil cables wherever possible.
- Route power cables along the rails.
- Route inter-cradle cables to the side rails and then from the rails to the bracket.

5-Slot Cradle Wall Installation

Use the Rack/Wall Mount Bracket to mount a cradle on a wall. When installing on a wall, first assemble the bottom tray, install the bottom tray on the wall and then assemble the top tray.

Fasten the mounting bracket to the wall using appropriate screws and/or anchors. The Mount Bracket mounting slots dimensions are 5 mm (0.2 in.). Fasteners must be able to hold a minimum of 20 Kg (44 lbs).

For proper installation consult a professional installer. Failure to install the bracket properly can possibly result in damage to the hardware.

Bottom Tray Assembly

See steps 1 through 5 on [page 129](#) for instructions.

Bracket Wall Mounting

1. Drill holes and install anchors according to the template supplied with the bracket.
2. Install two screws for bottom of bracket. The screw heads should protrude 2.5 mm (0.01 in.) from the wall.

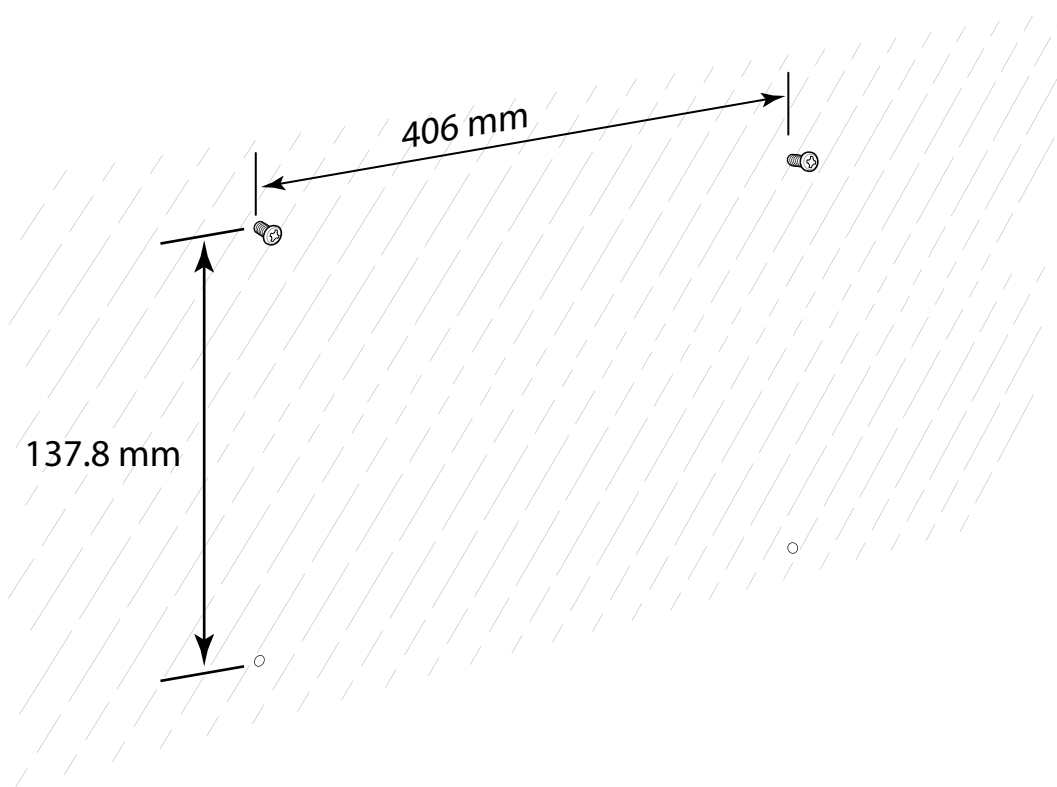

3. Align the mounting bracket's bottom mounting key holes with the screws.

4. Hang the bracket on the screws.

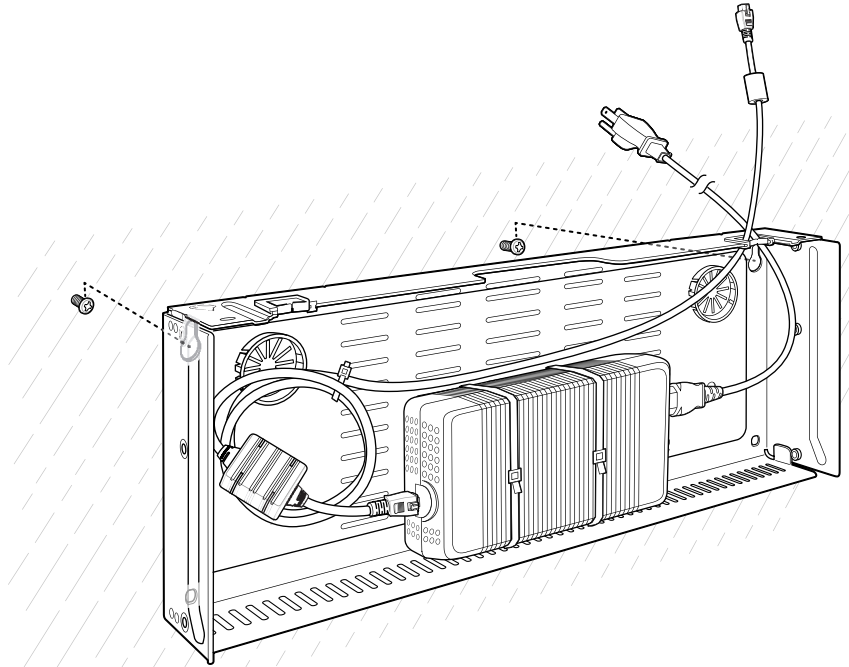

5. Install two top screws.
6. Tighten all screws.

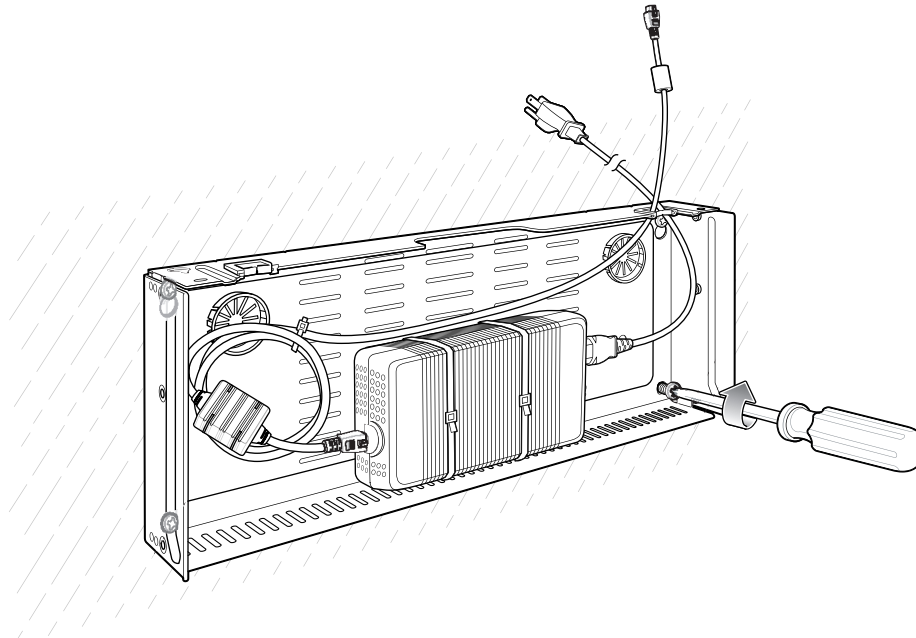

7. Assemble the top tray. See steps 6 through 8 on [page 129](#).
8. Slide the assembled top tray onto bottom tray.
9. Connect cables to cradle.
10. Secure top tray to bottom tray with four M5 screws (two on each side).
11. Route cables and connect to power source.



CAUTION: Installer should ensure that all building codes are followed when connecting the power supplies to an AC power source.

While installing the brackets, power supplies and cables:

- Use tie wraps to secure cables to the bracket.
- Coil cables wherever possible.
- Route power cables along wall and secure.

4-Slot Battery Charger Wall Installation

Use the Rack/Wall Mount Bracket to mount four 4-Slot Battery Chargers a cradle on a wall. When installing on a wall, first assemble the bottom tray, install the bottom tray on the wall and then assemble the top tray.

Fasten the mounting bracket to the wall using appropriate screws and/or anchors. The Mount Bracket mounting slots dimensions are 5 mm (0.2 in.). Fasteners must be able to hold a minimum of 20 Kg (44 lbs).

For proper installation consult a professional installer. Failure to install the bracket properly can possibly result in damage to the hardware.

Bottom Tray Assembly

See steps 1 through 5 on [page 129](#) for instructions.

Bracket Wall Mounting

1. Drill holes and install anchors according to the template supplied with the bracket.
2. Install two screws for bottom of bracket. The screw heads should protrude 2.5 mm (0.01 in.) from the wall.

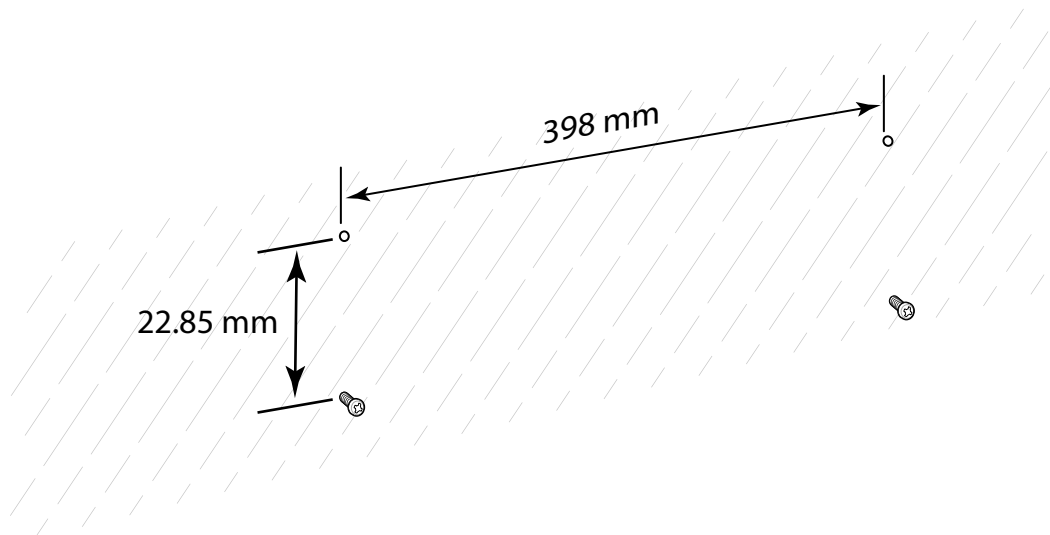

3. Align the mounting bracket's bottom mounting key holes with the screws.

4. Hang the bracket on the screws.

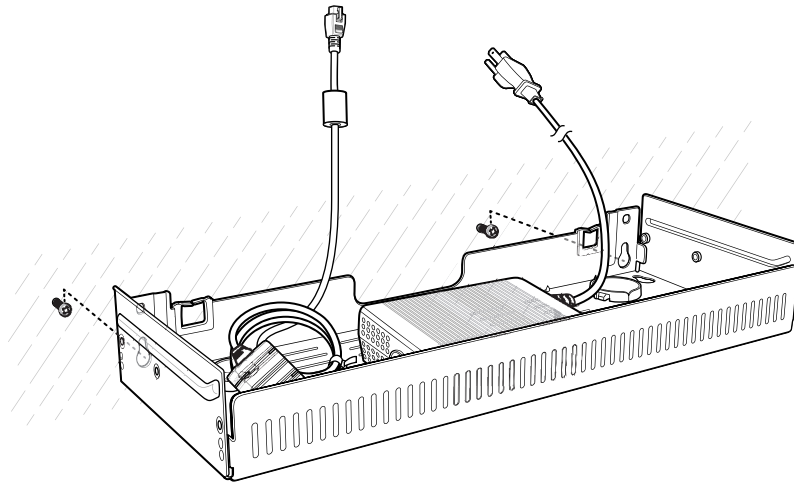

5. Install two top screws.
6. Tighten all screws.

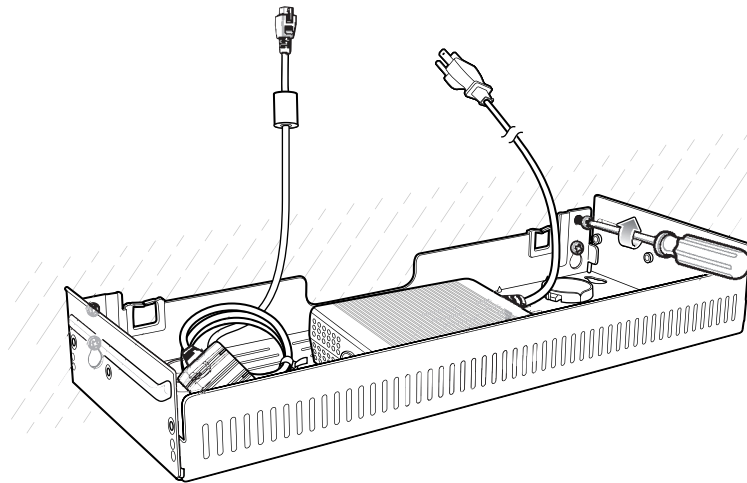

7. Assemble the four 4-Slot Battery Chargers onto the bracket. See steps 9 through 11 on [page 133](#).
8. Route cables and connect to power source.



CAUTION: Installer should ensure that all building codes are followed when connecting the power supplies to an AC power source.

While installing the brackets, power supplies and cables:

- Use tie wraps to secure cables to the bracket and rails.
- Coil cables wherever possible.
- Route power cables along the rails.
- Route inter-cradle cables to the side rails and then from the rails to the bracket.

Application Deployment

Security

The device implements a set of security policies that determine whether an application is allowed to run and, if allowed, with what level of trust. To develop an application, you must know the security configuration of the device, and how to sign an application with the appropriate certificate to allow the application to run (and to run with the needed level of trust).



NOTE: Ensure the date is set correctly before installing certificates or when accessing secure web sites.

Secure Certificates

If the VPN or Wi-Fi networks rely on secure certificates, obtain the certificates and store them in the device's secure credential storage, before configuring access to the VPN or Wi-Fi networks.

If downloading the certificates from a web site, set a password for the credential storage. The device supports X.509 certificates saved in PKCS#12 key store files with a .p12 extension (if key store has a .pfx or other extension, change to .p12).

The device also installs any accompanying private key or certificate authority certificates contained in the key store.

Installing a Secure Certificate

To install a secure certificate:

1. Copy the certificate from the host computer to the root of the device's internal memory. See USB Communication for information about connecting the device to a host computer and copying files.
2. Go to **Settings**.
3. Touch **Security > Encryption & credentials**.
4. Touch **Install from storage**.
5. Navigate to the location of the certificate file.
6. Touch the filename of the certificate to install.
7. If prompted, enter the password for credential storage. If a password has not been set for the credential storage, enter a password for it twice and then touch **OK**.
8. If prompted, enter the certificate's password and touch **OK**.
9. Enter a name for the certificate and in the Credential use drop-down, select **VPN and apps** or **Wi-Fi**.

10. Touch **OK**.

The certificate can now be used when connecting to a secure network. For security, the certificate is deleted from the internal memory.

Configuring Credential Storage Settings

1. Go to **Settings**.
2. Touch **Security > Encryption & credentials**.
 - **Trusted credentials** - Touch to display the trusted system credentials.
 - **User credentials** - Touch to display user credentials.
 - **Install from storage** - Touch to install a secure certificate from the internal storage.
 - **Clear credentials** - Deletes all secure certificates and related credentials.

Development Tools

Development tools for Android include Android Studio, EMDK for Android, and StageNow.

Android Application Development

Development Workstation

Android development tools are available at developer.android.com.

To start developing applications for the device, download Android Studio. Development can take place on a Microsoft® Windows®, Mac® OS X®, or Linux® operating system.

Applications are written in Java or Kotlin, but compiled and executed in the Dalvik virtual machine. Once the Java code is compiled cleanly, the developer tools make sure the application is packaged properly, including the AndroidManifest.xml file.

Android Studio contains a full featured IDE as well as SDK components required to develop Android applications.

Enabling Developer Options

The **Developer options** screen sets development related settings. By default, the Developer Options are hidden.

1. Go to **Settings**.
2. Touch **About phone**.
3. Scroll down to **Build number**.
4. Tap **Build number** seven times. The message **You are now a developer!** appears.
5. Touch the Back button.
6. Touch **System > Advanced > Developer options**.
7. Slide the **USB debugging** switch to the **ON** position.

EMDK for Android

EMDK for Android provides developers with tools to create business applications for enterprise mobile devices. It is designed for use with Google's Android Studio and includes Android class libraries such as Barcode, sample applications with source code, and the associated documentation.

EMDK for Android allows applications to take full advantage of the capabilities that Zebra devices have to offer. It embeds Profile Manager technology within Android Studio IDE, providing a GUI-based development tool designed specifically for Zebra devices. This allows fewer lines of code, resulting in reduced development time, effort, and errors.

For more information go to: techdocs.zebra.com.

StageNow

StageNow is Zebra's next-generation Android Staging Solution built on the MX platform. It allows quick and easy creation of device profiles, and can deploy to devices simply by scanning a barcode, reading a tag, or playing an audio file.

The StageNow Staging Solution includes the following components:

- The StageNow Workstation tool installs on the staging workstation (host computer) and lets the administrator easily create staging profiles for configuring device components, and perform other staging actions such as checking the condition of a target device to determine suitability for software upgrades or other activities. The StageNow Workstation stores profiles and other created content for later use.
- The StageNow Client resides on the device and provides a user interface for the staging operator to initiate staging. The operator uses one or more of the desired staging methods (print and scan a barcode, read an NFC tag or play an audio file) to deliver staging material to the device.

For more information go to: techdocs.zebra.com.

GMS Restricted

GMS Restricted mode deactivates Google Mobile Services (GMS). All GMS apps are disabled on the device and communication with Google (analytics data collection and location services) is disabled.

Use StageNow to disable or enable GMS Restricted mode. After a device is in GMS Restricted mode, enable and disable individual GMS apps and services using StageNow. To ensure GMS Restricted mode persists after an Enterprise Reset, use the Persist Manager option in StageNow. For more information on StageNow, refer to techdocs.zebra.com.

ADB USB Setup

To use the ADB, install the USB driver. This assumes that the development SDK has been installed on the host computer. Go to developer.android.com/sdk/index.html for details on setting up the development SDK.

ADB driver for Windows and Linux are available on the Zebra Support Central web site at www.zebra.com/support. Download the ADB and USB Driver Setup package. Follow the instructions with the package to install the ADB and USB drivers for Windows and Linux.

Enabling USB Debugging

By default, USB debugging is disabled.

1. Go to **Settings**.
2. Touch **About phone**.
3. Scroll down to **Build number**.
4. Tap **Build number** seven times. The message **You are now a developer!** appears.
5. Touch the Back button.
6. Touch **System > Advanced > Developer options**.
7. Slide the **USB debugging** switch to the **ON** position.
8. Touch **OK**.
9. Connect the device to the host computer using the Rugged Charge/USB Cable.
The **Allow USB debugging?** dialog box appears on the device.
10. On the device, touch **OK**.
11. On the host computer, navigate to the **platform-tools** folder.
12. Type **adb devices**.
The following displays:
List of devices attached
XXXXXXXXXXXXXXXXX device (where XXXXXXXXXXXXXXXXXXXX is the device number).



NOTE: If device number does not appear, ensure that ADB drivers are installed properly.

13. Touch the Home button.

Application Installation

After an application is developed, install the application onto the device using one of the following methods:

- USB connection, see [Installing Applications Using the USB Connection on page 145](#).
- Android Debug Bridge, see [Installing Applications Using the Android Debug Bridge on page 146](#).
- Mobile device management (MDM) platforms that have application provisioning. Refer to the MDM software documentation for details.

Installing Applications Using the USB Connection

1. Pull down the Notification panel and touch **Charging this device via USB**.
2. Touch **File Transfer**.
3. On the host computer, open a file manager application.
4. On the host computer, copy the application .apk file from the host computer to the device.
5. Disconnect the device from the host computer.
6. Swipe the screen up and select  to view files on the Internal Storage.
7. Locate the application .apk file.

8. Touch the application file.
9. Touch **Continue** to install the app or **Cancel** to stop the installation.
10. To confirm installation and accept what the application affects, touch **Install** otherwise touch **Cancel**.
11. Touch **Open** to open the application or **Done** to exit the installation process. The application appears in the App list.

Installing Applications Using the Android Debug Bridge

Use ADB commands to install application onto the device.

1. Ensure that the ADB drivers are installed on the host computer. See [ADB USB Setup on page 144](#).
2. Connect the device to a host computer using USB. See [USB Communication on page 29](#).
3. Go to **Settings**.
4. Touch **System > Advanced > Developer options**.
5. Slide the switch to the **ON** position.
6. Touch **USB Debugging**. A check appears in the check box. The **Allow USB debugging?** dialog box appears.
7. Touch **OK**.
8. On the host computer, open a command prompt window and use the adb command:
`adb install <application>`
where: <application> = the path and filename of the apk file.
9. Disconnect the device from the host computer. See [USB Communication on page 29](#).

Uninstalling an Application

1. Go to **Settings**.
2. Touch **Apps & notifications**.
3. Touch **See all apps** to view all apps in the list.
4. Scroll through the list to the app.
5. Touch the app. The **App info** screen appears.
6. Touch **Uninstall**.
7. Touch **OK** to confirm.

Performing a System Update

System Update packages can contain either partial or complete updates for the operating system. Zebra distributes the System Update packages on the Zebra Support & Downloads web site. Perform a system update using ADB.

Downloading the System Update Package

1. Go to the Zebra Support & Downloads web site, www.zebra.com/support.
2. Download the appropriate System Update package to a host computer.

Performing a System Update Using ADB

1. Go to **Settings**.
2. Touch **System > Advanced > Developer options**.
3. Slide the switch to the **ON** position.
4. Touch **USB Debugging**. A check appears in the check box. The **Allow USB debugging?** dialog box appears.
5. Touch **OK**.
6. On the host computer, open a command prompt window and use the adb command:

```
adb devices
```

The following displays:
List of devices attached
XXXXXXXXXXXXXXXXX device (where XXXXXXXXXXXXXXXXXXXX is the device number).



NOTE: If device number does not appear, ensure that ADB drivers are installed properly.

7. Type:

```
adb reboot recovery
```
8. Press Enter. The System Recovery screen appears on the device.
9. On the host computer command prompt window type:

```
adb sideload <file>
```

where: <file> = the path and filename of the zip file.
10. Press Enter. The System Update installs (progress appears as percentage in the Command Prompt window) and then the System Recovery screen appears on the device.

Verifying System Update Installation

1. Go to **Settings**.
2. Touch **About phone**.
3. Scroll down to **Build number**.
4. Ensure that the build number matches the new system update package file number.

Enterprise Reset

An Enterprise Reset erases all user data in the `/data` partition, including data in the primary storage locations (`/sdcard` and emulated storage).

Before performing an Enterprise Reset, provision all necessary configuration files and restore after the reset.

Performing an Enterprise Reset From Device Settings

1. Go to **Settings**.
2. Touch **System > Reset options > Erase all data (enterprise reset)**.

3. Touch **Erase all data** twice to confirm the Enterprise Reset.

Downloading the Enterprise Reset Package

1. Go to the Zebra Support & Downloads web site, www.zebra.com/support.
2. Download the Enterprise Reset file to a host computer.

Performing an Enterprise Reset Using ADB

1. Go to **Settings**.
2. Touch **System > Advanced > Developer options**.
3. Slide the switch to the **ON** position.
4. Touch **USB Debugging**. A check appears in the check box. The **Allow USB debugging?** dialog box appears.
5. Touch **OK**.
6. On the host computer, open a command prompt window and type:

adb devices.

The following displays:

List of devices attached

XXXXXXXXXXXXXXXXX device (where XXXXXXXXXXXXXXXXXXXX is the device number).



NOTE: If device number does not appear, ensure that ADB drivers are installed properly.

7. Type:
adb reboot recovery
8. Press Enter. The System Recovery screen appears on the device.
9. On the host computer command prompt window type:
adb sideload <file>
where: <file> = the path and filename of the zip file.
10. Press Enter. The Enterprise Reset package installs and then the System Recovery screen appears on the device.

Performing a Factory Reset

A Factory Reset erases all data in the **/data** and **/enterprise** partitions in internal storage and clears all device settings. A Factory Reset returns the device to the last installed operating system image. To revert to a previous operating system version, re-install that operating system image. See [Performing a System Update](#) for more information.

Downloading the Factory Reset Package

To download the Factory Reset package:

1. Go to the Zebra Support & Downloads web site, www.zebra.com/support.
2. Download the appropriate Factory Reset file to a host computer.

Performing a Factory Reset Using ADB

To perform an Factory Reset using ADB:

1. Go to **Settings**.
2. Touch **System > Advanced > Developer options**.
3. Slide the switch to the **ON** position.
4. Touch **USB Debugging**. A check appears in the check box. The **Allow USB debugging?** dialog box appears.
5. Touch **OK**.
6. On the host computer, open a command prompt window and type:

```
adb devices.
```

The following displays:

```
List of devices attached
```

```
XXXXXXXXXXXXXXXXX device (where XXXXXXXXXXXXXXXXXXXX is the device number).
```



NOTE: If device number does not appear, ensure that ADB drivers are installed properly.

7. Type:

```
adb reboot recovery
```
8. Press Enter. The System Recovery screen appears on the device.
9. On the host computer command prompt window type:

```
adb sideload <file>
```

where: <file> = the path and filename of the zip file.
10. Press Enter. The Factory Reset package installs and then the System Recovery screen appears on the device.

Storage

The device contains the following types of file storage:

- Random Access Memory (RAM)
- Internal storage
- Enterprise folder.

Random Access Memory

Executing programs use RAM to store data. Data stored in RAM is lost upon a reset. The operating system manages how applications use RAM. It only allows applications and component processes and services to use RAM when required. It may cache recently used processes in RAM, so they restart more quickly when opened again, but it will erase the cache if it needs the RAM for new activities.

The screen displays the amount of used and free RAM.

- **Performance** - Indicates memory performance.
- **Total memory** - Indicates the total amount of RAM available.

- **Average used (%)** - Indicates the average amount of memory (as a percentage) used during the period of time selected (default - 3 hours).
- **Free** - Indicates the total amount of unused RAM.
- **Memory used by apps** - Touch to view RAM usage by individual apps.

Viewing Memory

1. Go to **Settings**.
2. Touch **System > Advanced > Developer options > Memory**.

Internal Storage

The device has internal storage. The internal storage content can be viewed and files copied to and from when the device is connected to a host computer. Some applications are designed to be stored on the internal storage rather than in internal memory.

Viewing Internal Storage

1. Go to **Settings**.
2. Touch **Storage**.

Enterprise Folder

The Enterprise folder (within internal flash) is a super-persistent storage that is persistent after a reset and an Enterprise Reset. The Enterprise folder is erased during a Factory Reset. The Enterprise folder is used for deployment and device-unique data. The Enterprise folder is approximately 128 MB (formatted). Applications can persist data after an Enterprise Reset by saving data to the enterprise/user folder. The folder is ext4 formatted and is only accessible from a host computer using ADB or from an MDM.

Managing Apps

Apps use two kinds of memory: storage memory and RAM. Apps use storage memory for themselves and any files, settings, and other data they use. They also use RAM when they are running.

1. Go to **Settings**.
2. Touch **Apps & notifications**.
3. Touch **See all XX apps** to view all apps on the device.
4. Touch **⋮ > Show system** to include system processes in the list.
5. Touch an app, process, or service in the list to open a screen with details about it and, depending on the item, to change its settings, permissions, notifications and to force stop or uninstall it.

App Details



Apps have different kinds of information and controls.

- **Force stop** - Stop an app.
- **Disable** - Disable an app.
- **Uninstall** - Remove the app and all of its data and settings from the device. See Uninstalling an Application for information about uninstalling apps.

- **Notifications** - Set the app notification settings.
- **Permissions** - Lists the areas on the device that the app has access to.
- **Storage & cache** - Lists how much information is stored, and includes buttons for clearing it.
- **Mobile data & Wi-Fi** - Provides information about data consumed by an app.
- **Advanced**
 - **Screen time** - Displays the amount of time the app has displayed on the screen.
 - **Battery** - Lists the amount of computing power used by the app.
 - **Open by default** - If you have configured an app to launch certain file types by default, you can clear that setting here.
 - **Display over other apps** - allows an app to display on top of other apps.
 - **App details** - Provides a link to additional app details on the Play store.
 - **Additional settings in the app** - Opens settings in the app.
 - **Modify system settings** - Allows an app to modify the system settings.

Managing Downloads

Files and apps downloaded using the Browser or Email are stored on the Internal storage in the Download directory. Use the Downloads app to view, open, or delete downloaded items.

1. Swipe the screen up and touch .
2. Touch  > **Downloads**.
3. Touch and hold an item, select items to delete and touch . The item is deleted from the device.

Maintenance and Troubleshooting

Maintaining the Device

For trouble-free service, observe the following tips when using the device:

- To avoid scratching the screen, use a Zebra approved capacitive compatible stylus intended for use with a touch-sensitive screen. Never use an actual pen or pencil or other sharp object on the surface of the device screen.
- The touch-sensitive screen of the device is glass. Do not drop the device or subject it to strong impact.
- Protect the device from temperature extremes. Do not leave it on the dashboard of a car on a hot day, and keep it away from heat sources.
- Do not store the device in any location that is dusty, damp, or wet.
- Use a soft lens cloth to clean the device. If the surface of the device screen becomes soiled, clean it with a soft cloth moistened with an approved cleanser. For a list of approved cleansers, see Approved Cleanser Active Ingredients.

Battery Safety Guidelines

- The area in which the units are charged should be clear of debris and combustible materials or chemicals. Particular care should be taken where the device is charged in a non commercial environment.
- Follow battery usage, storage, and charging guidelines found in this guide.
- Improper battery use may result in a fire, explosion, or other hazard.
- To charge the mobile device battery, the ambient battery and charger temperatures must be between +32°F and +104°F (0°C and +40°C).
- Do not use incompatible batteries and chargers, including non-Zebra batteries and chargers. Use of an incompatible battery or charger may present a risk of fire, explosion, leakage, or other hazard. If you have any questions about the compatibility of a battery or a charger, contact the Global Customer Support Center.
- For devices that utilize a USB port as a charging source, the device shall only be connected to products that bear the USB-IF logo or have completed the USB-IF compliance program.
- Do not disassemble or open, crush, bend or deform, puncture, or shred the battery.
- Severe impact from dropping any battery-operated device on a hard surface could cause the battery to overheat.
- Do not short circuit a battery or allow metallic or conductive objects to contact the battery terminals.
- Do not modify or remanufacture, attempt to insert foreign objects into the battery, immerse or expose to water or other liquids, or expose to fire, explosion, or other hazard.

- Do not leave or store the equipment in or near areas that might get very hot, such as in a parked vehicle or near a radiator or other heat source. Do not place battery into a microwave oven or dryer.
- Battery usage by children should be supervised.
- Please follow local regulations to properly dispose of used rechargeable batteries.
- Do not dispose of batteries in fire.
- In the event of a battery leak, do not allow the liquid to come in contact with the skin or eyes. If contact has been made, wash the affected area with water for 15 minutes, and seek medical advice.
- If you suspect damage to your equipment or battery, contact Customer Support to arrange for inspection.

Cleaning Instructions



CAUTION: Always wear eye protection.

Read warning label on alcohol product before using.

If you have to use any other solution for medical reasons please contact the Global Customer Support Center for more information.



WARNING: Avoid exposing this product to contact with hot oil or other flammable liquids. If such exposure occurs, unplug the device and clean the product immediately in accordance with these guidelines.

Approved Cleanser Active Ingredients

100% of the active ingredients in any cleaner must consist of one or some combination of the following: isopropyl alcohol, or mild dish soap.



IMPORTANT: Use pre-moistened wipes and do not allow liquid cleaner to pool.

Approved cleaners include:

- Purell Ethanol Wipes
- 409 Glass Cleaner
- Windex Blue

Harmful Ingredients

The following chemicals are known to damage the plastics on the device and should not come in contact with the device: acetone; ketones; ethers; aromatic and chlorinated hydrocarbons; aqueous or alcoholic alkaline solutions; ethanolamine; toluene; trichloroethylene; benzene; carboric acid and TB-lysoform.

Many vinyl gloves contain phthalate additives, which are often not recommended for medical use and are known to be harmful to the housing of the device.

Device Cleaning Instructions

Do not apply liquid directly to the device. Dampen a soft cloth or use pre-moistened wipes. Do not wrap the device in the cloth or wipe, instead gently wipe the unit. Be careful not to let liquid pool around the display window or other places. Before use, allow the unit to air dry.



NOTE: For thorough cleaning, it is recommended to first remove all accessory attachments, such as hand straps or cradle cups, from the mobile device and to clean them separately.

Special Cleaning Notes

Do not handle the device while wearing vinyl gloves containing phthalates. Remove vinyl gloves and wash hands to eliminate any residue left from the gloves.

If products containing any of the harmful ingredients listed above are used prior to handling the device, such as a hand sanitizer that contains ethanalamine, hands must be completely dry before handling the device to prevent damage to the device.



IMPORTANT: If the battery connectors are exposed to cleaning agents, thoroughly wipe off as much of the chemical as possible and clean with an alcohol wipe. It is also recommended to install the battery in the terminal prior to cleaning and disinfecting the device to help minimize buildup on the connectors.

When using cleaning/disinfectant agents on the device, it is important to follow the directions prescribed by the cleaning/disinfectant agent manufacturer.

Cleaning Materials Required

- Alcohol wipes
- Lens tissue
- Cotton-tipped applicators
- Isopropyl alcohol
- Can of compressed air with a tube.

Cleaning Frequency

The cleaning frequency is at the customer's discretion due to the varied environments in which the mobile devices are used and may be cleaned as frequently as required. When dirt is visible, it is recommended to clean the mobile device to avoid build up of particles which make the device more difficult to clean later on.

Cleaning the Device

Housing

Thoroughly wipe the housing, including all buttons and triggers, using an approved alcohol wipe.

Display

The display can be wiped down with an approved alcohol wipe, but care should be taken not to allow any pooling of liquid around the edges of the display. Immediately dry the display with a soft, non-abrasive cloth to prevent streaking.

Exit Window

Wipe the exit window periodically with a lens tissue or other material suitable for cleaning optical material such as eyeglasses.

Cleaning Cradle Connectors

1. Remove the DC power cable from the cradle.
2. Dip the cotton portion of the cotton-tipped applicator in isopropyl alcohol.
3. Rub the cotton portion of the cotton-tipped applicator along the pins of the connector. Slowly move the applicator back-and-forth from one side of the connector to the other. Do not leave any cotton residue on the connector.
4. All sides of the connector should also be rubbed with the cotton-tipped applicator.
5. Remove any lint left by the cotton-tipped applicator.
6. If grease and other dirt can be found on other areas of the cradle, use a lint-free cloth and alcohol to remove.
7. Allow at least 10 to 30 minutes (depending on ambient temperature and humidity) for the alcohol to air dry before applying power to cradle.

If the temperature is low and humidity is high, longer drying time is required. Warm temperature and low humidity requires less drying time.



CAUTION: After cleaning the cradle connectors with bleach-based chemicals, follow the Cleaning Cradle Connectors instructions to remove bleach from the connectors.

Cleaning the Wrist Mount

It may be necessary to wash the wrist mount strap and replaceable comfort pad when they become soiled.

Figure 70 Wrist Mount

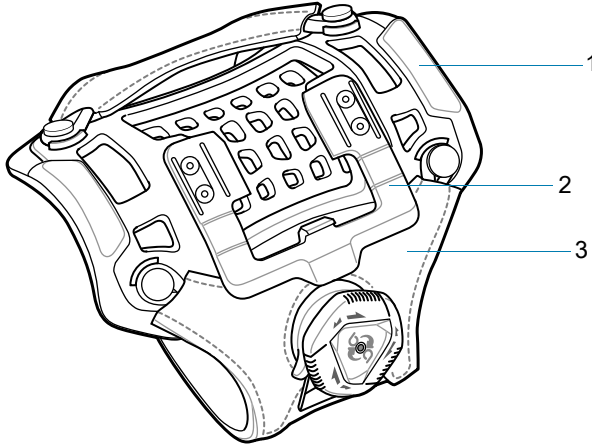

1	Comfort pad
2	Carriage
3	Strap

Remove the strap and comfort pad from the wrist mount. Hand wash in cold water with a mild detergent (such as Woolite®). Do not use bleach. Air dry. Do not use a dryer.

Figure 71 Comfort Pad

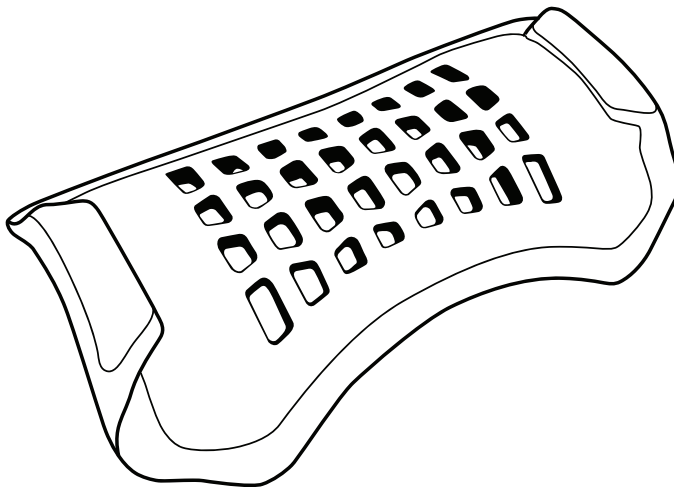

Figure 72 Strap

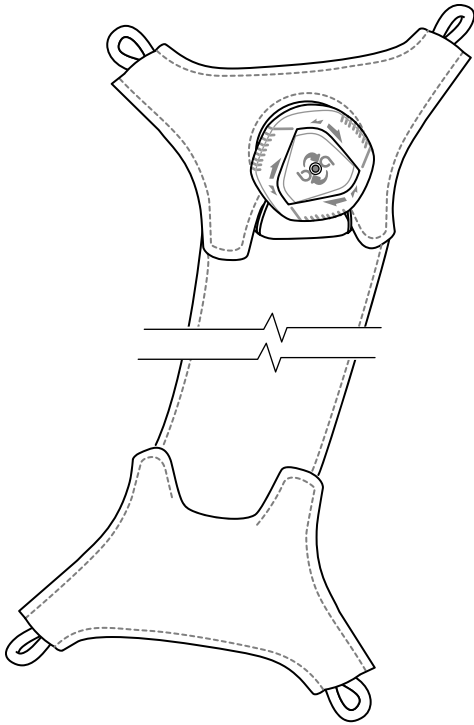
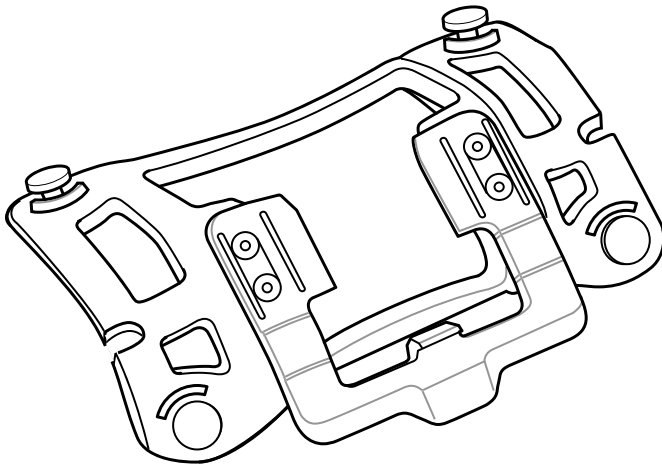

Figure 73 Carriage



Troubleshooting

Resetting the Device

There are two reset functions, soft reset and hard reset.

Performing a Soft Reset

Perform a soft reset if applications stop responding.

1. Press the **Power** button until the menu appears.
2. Touch **Reset**.
3. The device reboots.

Performing a Hard Reset



CAUTION: Perform a hard reset only if the device stops responding.

1. Simultaneously press and hold the **Power**, **P1** and **P2** buttons for five seconds.
2. When the screen turns off, release the buttons.
3. The device reboots.

WT6300

The following table describes possible problems, causes, and solutions for troubleshooting the device.

Table 18 Troubleshooting the WT6300

Problem	Cause	Solution
Device does not turn on.	Battery not charged.	Charge or replace the battery in the device.
	Battery not installed properly.	Ensure battery is installed properly. See Installing the Battery on page 17 .
	System crash.	Perform a soft reset. If the device still does not turn on, perform a hard reset.
Battery did not charge.	Battery failed.	Replace battery. If the device still does not operate, try a soft reset, then a hard reset.
	Device removed from cradle before charging completed.	Insert the device into the cradle and begin charging. The battery fully charges in approximately four hours.
	Ambient temperature of the cradle is too warm or too cold.	The ambient temperature must be between 0°C and 40°C (32 °F and 104°F).

Table 18 Troubleshooting the WT6300

Problem	Cause	Solution
During data communication, no data was transmitted, or transmitted data was incomplete.	Device unplugged from host computer during communication.	Reconnect the programming cable to the host computer and re-transmit.
	Communication software was incorrectly installed or configured.	See system administrator.
Device turns itself off.	Device is inactive.	The device turns off after a period of inactivity. If the device is running on battery power, this period can be set to 15 seconds, 30 seconds, 1 minute, 2 minutes, 5 minutes, 10 minutes, or 30 minutes. Change the setting if you need a longer delay before the automatic shutoff feature activates.
	Battery is depleted.	Place the device in the cradle to re-charge the battery.
	Battery is not inserted properly.	Insert the battery properly (see Installing the Battery on page 17).
	The device's battery is low and it powers down to protect memory content.	Place the device in the cradle to re-charge the battery.
A message appears stating that the device's memory is full.	Too many files stored on the device.	Delete unused memos and records. You can save these records on the host computer.
	Too many applications installed on the device.	If you have installed additional applications on the device, remove them to recover memory.
The device does not accept scan input from optional scanner.	Unreadable bar code.	Ensure the symbol is not defaced.
	Distance between scanner exit window and bar code is incorrect.	Move the scanner closer or further from the bar code to the proper scanning range.
	Device is not programmed for the bar code.	Verify that the device can read the type of bar code being scanned. Ensure that the bar code parameters are set properly for the bar code being scanned.
	Device is not programmed to generate a beep.	Verify that a beep on a good decode is used.
During USB data communications, no data was transmitted, or transmitted data was incomplete.	Incorrect cable connection.	See the Accessories section.
	Communications software is not installed or configured properly.	Perform setup as described in the Accessories section.

1-Slot Charging Cradle

Table 19 Troubleshooting the 1-Slot Charging Cradle

Symptom	Possible Cause	Action
LEDs do not light when device or spare battery is inserted.	Cradle is not receiving power.	Ensure the power cable is connected securely to both the cradle and to AC power.
	Device is not seated firmly in the cradle.	Remove and re-insert the device into the cradle, ensuring it is firmly seated.
	Spare battery is not seated firmly in the cradle.	Remove and re-insert the spare battery into the charging slot, ensuring it is firmly seated.
Device battery is not charging.	Device was removed from cradle or cradle was unplugged from AC power too soon.	Ensure cradle is receiving power. Ensure device is seated correctly. Confirm main battery is charging. The standard battery charges from fully depleted to 90% in approximately 4 hours, and the extended battery charges from fully depleted to 90% in approximately 5.5 hours.
	Battery is faulty.	Verify that other batteries charge properly. If so, replace the faulty battery.
	The device is not fully seated in the cradle.	Remove and re-insert the device into the cradle, ensuring it is firmly seated.
	Extreme battery temperature.	Battery does not charge if ambient temperature is below 0°C (32°F) or above 40°C (104°F).
Spare battery is not charging.	Battery not fully seated in charging slot.	Remove and re-insert the spare battery in the cradle, ensuring it is firmly seated. The standard battery charges from fully depleted to 90% in approximately 4 hours, and the extended battery charges from fully depleted to 90% in approximately 5.5 hours.
	Battery inserted incorrectly.	Re-insert the battery so the charging contacts on the battery align with the contacts on the cradle.
	Battery is faulty.	Verify that other batteries charge properly. If so, replace the faulty battery.

2-Slot Device/RS6000 Charging Cradle

Table 20 Troubleshooting the 2-Slot Device/RS6000 Charging Cradle

Symptom	Possible Cause	Action
LEDs do not light when device or scanner is inserted.	Cradle is not receiving power.	Ensure the power cable is connected securely to both the cradle and to AC power.
	Device is not seated firmly in the cradle.	Remove and re-insert the device into the cradle, ensuring it is firmly seated.
	Scanner is not seated firmly in the cradle.	Remove and re-insert the scanner into the charging slot, ensuring it is firmly seated.

Table 20 Troubleshooting the 2-Slot Device/RS6000 Charging Cradle (Continued)

Symptom	Possible Cause	Action
Device battery is not charging.	Device was removed from cradle or cradle was unplugged from AC power too soon.	Ensure cradle is receiving power. Ensure device is seated correctly. Confirm main battery is charging. The standard battery charges from fully depleted to 90% in approximately 4 hours, and the extended battery charges from fully depleted to 90% in approximately 5.5 hours.
	Battery is faulty.	Verify that other batteries charge properly. If so, replace the faulty battery.
	The device is not fully seated in the cradle.	Remove and re-insert the device into the cradle, ensuring it is firmly seated.
	Extreme battery temperature.	Battery does not charge if ambient temperature is below 0°C (32°F) or above 40°C (104°F).
Scanner battery is not charging.	Scanner was removed from cradle or cradle was unplugged from AC power too soon.	Ensure cradle is receiving power. Ensure scanner is seated correctly. Confirm main battery is charging.
	Battery is faulty.	Verify that other batteries charge properly. If so, replace the faulty battery.

5-Slot Charge Only Cradle Troubleshooting

Table 21 Troubleshooting the 5-Slot Charge Only Cradle

Problem	Cause	Solution
Battery is not charging.	Device removed from the cradle too soon.	Replace the device in the cradle. The standard battery charges from fully depleted to 90% in approximately 4 hours, and the extended battery charges from fully depleted to 90% in approximately 5.5 hours.
	Battery is faulty.	Verify that other batteries charge properly. If so, replace the faulty battery.
	Device is not inserted correctly in the cradle.	Remove the device and reinsert it correctly. Verify charging is active. Touch ⚙ > System > About phone > Status to view battery status.
	Ambient temperature of the cradle is too warm.	Move the cradle to an area where the ambient temperature is between 0°C (32°F) or above 40°C (104°F).

Table 21 Troubleshooting the 5-Slot Charge Only Cradle

Problem	Cause	Solution
Spare Battery not charging.	Charger is not receiving power.	Ensure the power cable is connected securely to both the charger and to AC power.
	Spare battery is not correctly seated.	Remove and re-insert the battery into the battery adapter, ensuring it is correctly seated.
	Battery adapter is not seated properly.	Remove and re-insert the battery adapter into the charger, ensuring it is correctly seated.
	Battery was removed from the charger or charger was unplugged from AC power too soon.	Ensure charger is receiving power. Ensure the spare battery is seated correctly. The standard battery charges from fully depleted to 90% in approximately 4 hours, and the extended battery charges from fully depleted to 90% in approximately 5.5 hours.
	Battery is faulty.	Verify that other batteries charge properly. If so, replace the faulty battery.

10-Slot Device/RS6000 Charge Only Cradle Troubleshooting

Table 22 Troubleshooting the 10-Slot Device/RS6000 Charge Only Cradle

Problem	Cause	Solution
Battery is not charging.	Device removed from the cradle too soon.	Replace the device in the cradle. The standard battery charges from fully depleted to 90% in approximately 4 hours, and the extended battery charges from fully depleted to 90% in approximately 5.5 hours.
	Battery is faulty.	Verify that other batteries charge properly. If so, replace the faulty battery.
	Device is not inserted correctly in the cradle.	Remove the device and reinsert it correctly. Verify charging is active. Touch ⚙ > System > About phone > Status to view battery status.
	Ambient temperature of the cradle is too warm.	Move the cradle to an area where the ambient temperature is between 0°C (+32°F) and +40°C (+104°F).

10-Slot Charge Only Cradle Troubleshooting

Table 23 Troubleshooting the 10-Slot Charge Only Cradle

Problem	Cause	Solution
Battery is not charging.	Device removed from the cradle too soon.	Replace the device in the cradle. The standard battery charges from fully depleted to 90% in approximately 4 hours, and the extended battery charges from fully depleted to 90% in approximately 5.5 hours.
	Battery is faulty.	Verify that other batteries charge properly. If so, replace the faulty battery.
	Device is not inserted correctly in the cradle.	Remove the device and reinsert it correctly. Verify charging is active. Touch ⚙ > System > About phone > Status to view battery status.
	Ambient temperature of the cradle is too warm.	Move the cradle to an area where the ambient temperature is between 0°C (+32°F) and +40°C (+104°F).

5-Slot Ethernet Cradle Troubleshooting

Table 24 Troubleshooting the 5-Slot Ethernet Cradle

Problem	Cause	Solution
During communication, no data transmits, or transmitted data was incomplete.	Device removed from cradle during communications.	Replace device in cradle and retransmit.
	Incorrect cable configuration.	Ensure that the correct cable configuration.
	Device has no active connection.	An icon is visible in the status bar if a connection is currently active.

Table 24 Troubleshooting the 5-Slot Ethernet Cradle

Problem	Cause	Solution
Battery is not charging.	Device removed from the cradle too soon.	Replace the device in the cradle. The standard battery charges from fully depleted to 90% in approximately 4 hours, and the extended battery charges from fully depleted to 90% in approximately 5.5 hours.
	Battery is faulty.	Verify that other batteries charge properly. If so, replace the faulty battery.
	Device is not inserted correctly in the cradle.	Remove the device and reinsert it correctly. Verify charging is active. Touch ⚙ > System > About phone > Status to view battery status.
	Ambient temperature of the cradle is too warm.	Move the cradle to an area where the ambient temperature is between 0°C (+32°F) and +40°C (+104°F).

4-Slot Spare Battery Charger Troubleshooting

Table 25 Troubleshooting the 4-Slot Battery Charger

Problem	Cause	Solution
Spare Battery Charging LED does not light when spare battery is inserted.	Spare battery is not correctly seated.	Remove and re-insert the spare battery into the charging slot, ensuring it is correctly seated.
Spare Battery not charging.	Charger is not receiving power.	Ensure the power cable is connected securely to both the charger and to AC power.
	Spare battery is not correctly seated.	Remove and re-insert the battery into the battery adapter, ensuring it is correctly seated.
	Battery adapter is not seated properly.	Remove and re-insert the battery adapter into the charger, ensuring it is correctly seated.
	Battery was removed from the charger or charger was unplugged from AC power too soon.	Ensure charger is receiving power. Ensure the spare battery is seated correctly. The standard battery charges from fully depleted to 90% in approximately 4 hours, and the extended battery charges from fully depleted to 90% in approximately 5.5 hours.
	Battery is faulty.	Verify that other batteries charge properly. If so, replace the faulty battery.

20-Slot Spare Battery Charger Troubleshooting

Table 26 Troubleshooting the 20-Slot Battery Charger

Problem	Cause	Solution
Spare Battery Charging LED does not light when spare battery is inserted.	Spare battery is not correctly seated.	Remove and re-insert the spare battery into the charging slot, ensuring it is correctly seated.
Spare Battery not charging.	Charger is not receiving power.	Ensure the power cable is connected securely to both the charger and to AC power.
	Spare battery is not correctly seated.	Remove and re-insert the battery into the battery adapter, ensuring it is correctly seated.
	Battery adapter is not seated properly.	Remove and re-insert the battery adapter into the charger, ensuring it is correctly seated.
	Battery was removed from the charger or charger was unplugged from AC power too soon.	Ensure charger is receiving power. Ensure the spare battery is seated correctly. The standard battery charges from fully depleted to 90% in approximately 4 hours, and the extended battery charges from fully depleted to 90% in approximately 5.5 hours.
	Battery is faulty.	Verify that other batteries charge properly. If so, replace the faulty battery.

Technical Specifications

For device technical specifications, go to www.zebra.com.

Table 27 Data Capture Options

Item	Description
1D Bar Codes	Chinese 2 of 5, Codabar, Code 11, Code 128, Code 39, Code 93, Discrete 2 of 5, EAN-8, EAN-13, GS1 DataBar, GS1 DataBar 14, GS1 DataBar Expanded GS1, GS1 DataBar Limited, Interleaved 2 of 5, Korean 2 of 5, Matrix 2 of 5, MSI, TLC39, Trioptic 39, UPCA, UPCE, UPCE1
2D Bar Codes	Australian Postal, Aztec, Canadian Postal, Composite AB, Composite C, Data Matrix, Dutch Postal, HAN XIN, Japanese Postal, Mail Mark, Maxi Code, Micro PDF-417, microQR, PDF-417, QR Code, US Planet, UK Postal, US Postnet, USPS 4-state (US4CB), US4state FICS

I/O Connector Pin-Outs

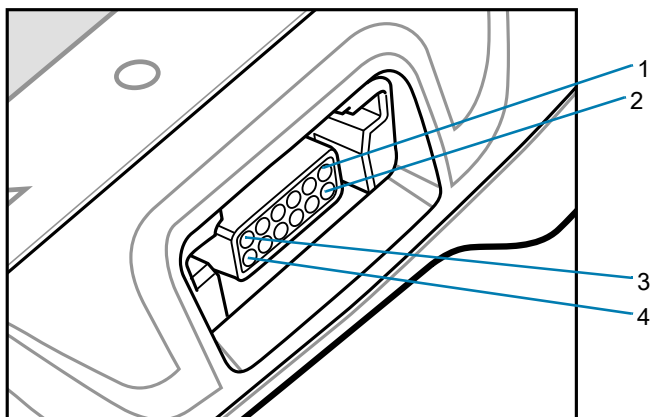

1	Pin 1
2	Pin 2
3	Pin 11
4	Pin 12

Table 28 I/O Connector Pin-Outs

Pin	Signal	Description
1	GND	Ground
2	DETECT	Detects connected accessory.
3	RX	UART Rx signal (scanner).
4	PWR_OUT	Power output (scanner).
5	USB_PWR PWR_OUT	USB VBUS Power (cradles). Power output (scanner and vibrator cable).
6	USB_ID UART_CTS MIC	USB ID pin (cradles). UART_CTS (scanner). Microphone input (wired headset).
7	PWR_IN	Input power (cradles).
8	PWR_IN	Input power (cradles).
9	TX SPEAKER VIBRATOR	UART Tx signal (cradles and scanner). Audio out (wired headset). Vibrator control signal (vibrator).
10	USB_D+ HW_TRIG PTT	USB Data D+ (cradles) Scan trigger detect (scanner). Push-to-Talk signal (wired headset).
11	USB_D- UART_RTS	USB Data D- (cradles) UART RTS signal (scanner).
12	GND	Ground

1-Slot USB Charging Cradle Technical Specifications

Table 29 1-Slot USB Charging Cradle Technical Specifications

Item	Description
Dimensions	Height: 81.8 mm (3.22 in.) Width: 97.5 mm (3.84 in.) Depth: 134.5 mm (5.30 in.)
Weight	424 g (15.0 oz.)
Input Voltage	12 VDC
Power Consumption	11.8 watts
Operating Temperature	0°C to 50°C (32°F to 122°F)
Storage Temperature	-40°C to 70°C (-40°F to 158°F)
Charging Temperature	0°C to 40°C (32°F to 104°F)
Humidity	5% to 95% non-condensing
Drop	76.2 cm (30.0 in.) drops to vinyl tiled concrete at room temperature.
Electrostatic Discharge (ESD)	+/- 20kV air +/- 10 kV contact +/- 10 kV indirect discharge

2-Slot Device/RS6000 Charging Cradle Technical Specifications

Table 30 2-Slot Device/RS6000 Charging Cradle Technical Specifications

Item	Description
Dimensions	Height: 81.8 mm (3.22 in.) Width: 97.5 mm (3.84 in.) Depth: 134.5 mm (5.30 in.)
Weight	448 g (15.8 oz.)
Input Voltage	12 VDC
Power Consumption	13.7 watts
Operating Temperature	0°C to 50°C (32°F to 122°F)
Storage Temperature	-40°C to 70°C (-40°F to 158°F)
Charging Temperature	0°C to 40°C (32°F to 104°F)
Humidity	0% to 95% non-condensing
Drop	76.2 cm (30.0 in.) drops to vinyl tiled concrete at room temperature.
Electrostatic Discharge (ESD)	+/- 20kV air +/- 10kV contact +/- 10kV indirect discharge

5-Slot Charge Only Cradle Technical Specifications

Table 31 5-Slot Charge Only Cradle Technical Specifications

Item	Description
Dimensions	Height: 86.3 mm (3.39 in.) Width: 489.0 mm (19.25 in.) Depth: 134.5 mm (5.30 in.)
Weight	2,228 g (78.6 oz.)
Input Voltage	12 VDC
Power Consumption	64.0 watts
Operating Temperature	0°C to 50°C (32°F to 122°F)
Storage Temperature	-40°C to 70°C (-40°F to 158°F)
Charging Temperature	0°C to 40°C (32°F to 104°F)
Humidity	0% to 95% non-condensing
Drop	76.2 cm (30.0 in.) drops to vinyl tiled concrete at room temperature.
Electrostatic Discharge (ESD)	+/- 20kV air +/- 10kV contact +/- 10kV indirect discharge

10-Slot Device/RS6000 Charge Only Cradle Technical Specifications

Table 32 10-Slot Device/RS6000 Charge Only Cradle Technical Specifications

Item	Description
Dimensions	Height: 86.3 mm (3.39 in.) Width: 489.0 mm (19.25 in.) Depth: 134.5 mm (5.30 in.)
Weight	2,164 g (76.33 oz.)
Input Voltage	12 VDC
Power Consumption	65.8 watts
Operating Temperature	0°C to 50°C (32°F to 122°F)
Storage Temperature	-40°C to 70°C (-40°F to 158°F)
Charging Temperature	0°C to 40°C (32°F to 104°F)
Humidity	5% to 95% non-condensing
Drop	76.2 cm (30.0 in.) drops to vinyl tiled concrete at room temperature.
Electrostatic Discharge (ESD)	+/- 20kV air +/- 10kV contact +/- 10kV indirect discharge

10-Slot Charge Only Cradle Technical Specifications

Table 33 10-Slot Charge Only Cradle Technical Specifications

Item	Description
Dimensions	Height: 86.3 mm (3.4 in.) Width: 489 mm (19.25 in.) Depth: 134.5 mm (5.3 in.)
Weight	2.2 kg (78.25 oz.)
Input Voltage	12 VDC
Power Consumption	71 watts
Operating Temperature	0°C to 50°C (32°F to 122°F)
Storage Temperature	-40°C to 70°C (-40°F to 158°F)
Charging Temperature	0°C to 40°C (32°F to 104°F)
Humidity	5% to 95% non-condensing
Drop	76.2 cm (30.0 in.) drops to vinyl tiled concrete at room temperature.
Electrostatic Discharge (ESD)	+/- 20kV air +/- 10kV contact +/- 10kV indirect discharge

5-Slot Ethernet Cradle Technical Specifications

Table 34 5-Slot Ethernet Cradle Technical Specifications

Item	Description
Dimensions	Height: 86.3 mm (3.4 in.) Width: 489 mm (19.25 in.) Depth: 134.5 mm (5.3 in.)
Weight	2.2 kg (78.6 oz.)
Input Voltage	12 VDC
Power Consumption	65.5 watts
Operating Temperature	0°C to 40°C (32°F to 104°F)
Storage Temperature	-40°C to 70°C (-40°F to 158°F)
Charging Temperature	0°C to 40°C (32°F to 104°F)
Humidity	5% to 95% non-condensing
Drop	76.2 cm (30.0 in.) drops to vinyl tiled concrete at room temperature.
Electrostatic Discharge (ESD)	+/- 20kV air +/- 10kV contact +/- 10kV indirect discharge

4-Slot Battery Charger Technical Specifications

Table 35 4-Slot Battery Charger Technical Specifications

Item	Description
Dimensions	Height: 62.4 mm (3.5 in.) Width: 97.5 mm (3.8 in.) Depth: 134.5 mm (5.3 in.)
Weight	422 g (14.9 oz.)
Input Voltage	12 VDC
Power Consumption	16.4 watts
Operating Temperature	0°C to 40°C (32°F to 104°F)
Storage Temperature	-40°C to 70°C (-40°F to 158°F)
Charging Temperature	0°C to 40°C (32°F to 104°F)
Humidity	5% to 95% non-condensing
Drop	76.2 cm (30.0 in.) drops to vinyl tiled concrete at room temperature.
Electrostatic Discharge (ESD)	+/- 20kV air +/- 10kV contact +/- 10kV indirect discharge

20-Slot Battery Charger Technical Specifications

Table 36 20-Slot Battery Charger Technical Specifications

Item	Description
Dimensions	Height: 66.9 mm (2.6 in.) Width: 489 mm (19.25 in.) Depth: 134.5 mm (5.3 in.)
Weight	2.2 kg (76.6 oz.)
Input Voltage	12 VDC
Power Consumption	97.8 watts
Operating Temperature	0°C to 40°C (32°F to 104°F)
Storage Temperature	-40°C to 70°C (-40°F to 158°F)
Charging Temperature	0°C to 40°C (32°F to 104°F)
Humidity	5% to 95% non-condensing
Drop	76.2 cm (30.0 in.) drops to vinyl tiled concrete at room temperature.
Electrostatic Discharge (ESD)	+/- 20kV air +/- 10kV contact +/- 10kV indirect discharge

USB and Charging Cable Technical Specifications

Table 37 USB and Charging Cable Technical Specifications

Item	Description
Length	160.3 cm (63 in.)
Input Voltage	5.4 VDC (external power supply)
Operating Temperature	-20°C to 50°C (-4°F to 122°F)
Storage Temperature	-40°C to 70°C (-40°F to 158°F)
Humidity	10% to 95% non-condensing
Electrostatic Discharge (ESD)	+/- 20kV air +/- 10kV contact

Short Quick Disconnect Headset Adapter Cable Technical Specifications

Table 38 Short Quick Disconnect Headset Adapter Cable Technical Specifications

Item	Description
Length	22.0 cm (8.7 in.)
Input Voltage	5.4 VDC
Operating Temperature	-20°C to 50°C (-4°F to 122°F)
Storage Temperature	-40°C to 70°C (-40°F to 158°F)
Humidity	10% to 95% non-condensing
Electrostatic Discharge (ESD)	+/- 20kV air +/- 10kV contact

Long Quick Disconnect Headset Adapter Cable Technical Specifications

Table 39 Long Quick Disconnect Headset Adapter Cable Technical Specifications

Item	Description
Length	47.5 cm (18.7 in.)
Operating Temperature	-20°C to 50°C (-4°F to 122°F)
Storage Temperature	-40°C to 70°C (-40°F to 158°F)
Humidity	10% to 95% non-condensing
Electrostatic Discharge (ESD)	+/- 20kV air +/- 10kV contact

Vibrator Cable Technical Specifications

Table 40 Vibrator Cable Technical Specifications

Item	Description
Length	31.8 cm (12.5 in.)
Operating Temperature	-20°C to 50°C (-4°F to 122°F)
Storage Temperature	-40°C to 70°C (-40°F to 158°F)
Humidity	10% to 95% non-condensing
Electrostatic Discharge (ESD)	+/- 20kV air +/- 10kV contact

